

STERLING CRANE



LIFTING CHARTS - Carry Decks

BRODERSON MODEL IC-80-1A - 8.5 TON CAPACITY

ALL CAPACITIES FOR 360° ROTATION

LOAD RADIUS FEET	3 - SECTION BOOM		10' BOOM EXTENSION INSTALLED	
	ON RUBBER	ON OUTRIGGERS	ON RUBBER	ON OUTRIGGERS
5	10700	17000	6700	7000
6	9500	14500	5950	6000
8	6400	10250	4750	5000
10	4450	7700	3900	4000
12	3400	6550	3325	3450
14	2675	5550	2975	3050
16	2175	4450	2600	2700
18	1840	3950	2125	2250
20	1550	3550	1800	2250
22			1500	2250
24			1300	2250
26			1100	2250
28			950	2125
30			800	1900

CRANE CAPACITY CHART

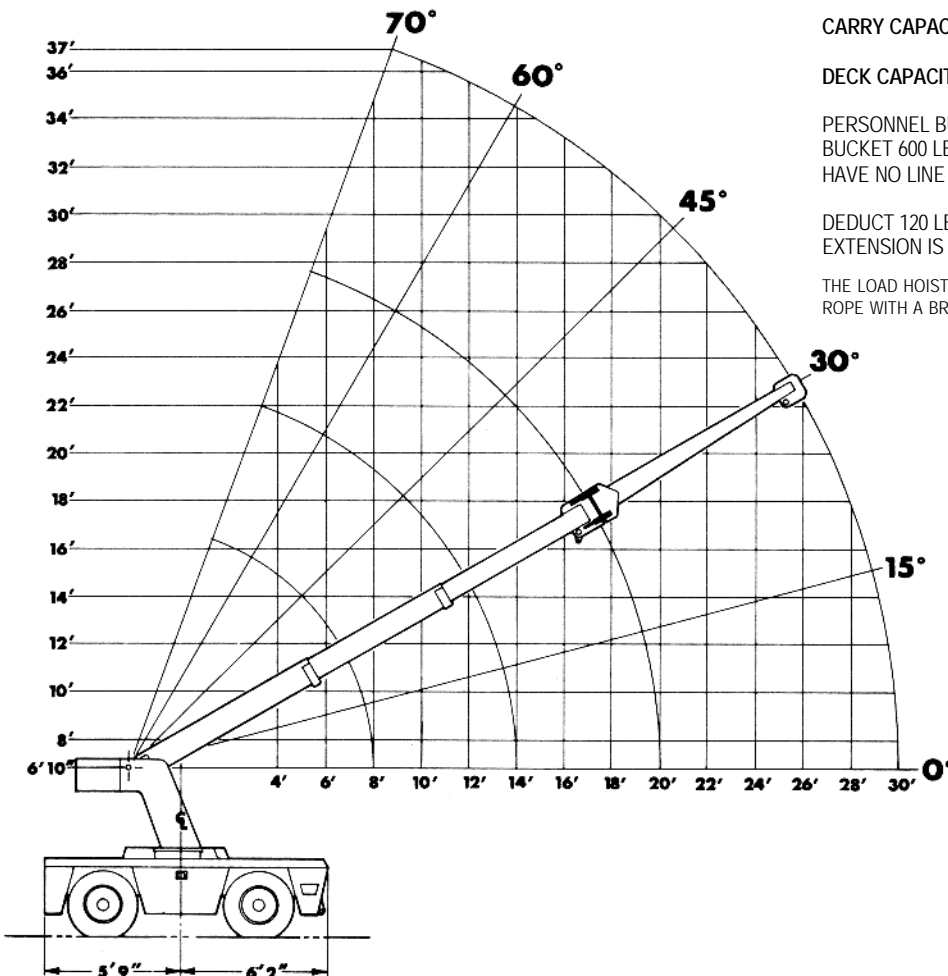
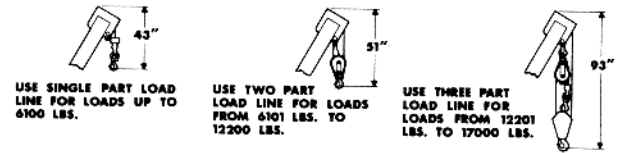

CARRY CAPACITY SPEED LIMIT 3 MPH

DECK CAPACITY 12000 LBS. (CENTERED OVER AXLE)

PERSONNEL BUCKET CAPACITY - OUTRIGGERS EXTENDED 300 LBS. PER BUCKET 600 LBS. TOTAL. THE BOOMS ON THIS UNIT ARE ALL STEEL AND HAVE NO LINE VOLTAGE RATING. MAXIMUM HYDRAULIC PRESSURE 3000 PSI.

DEDUCT 120 LBS. FROM ALL " ON RUBBER " CAPACITIES WHEN BOOM EXTENSION IS STOWED ON BASE BOOM.

THE LOAD HOIST LINE ON THIS UNIT SHOULD BE ½" DIA 6 X 25 - IP -IWRC WIRE ROPE WITH A BREAKING STRENGTH OF 21,700 LBS. WITH ROPE IN GOOD CONDITION.

STERLING CRANE

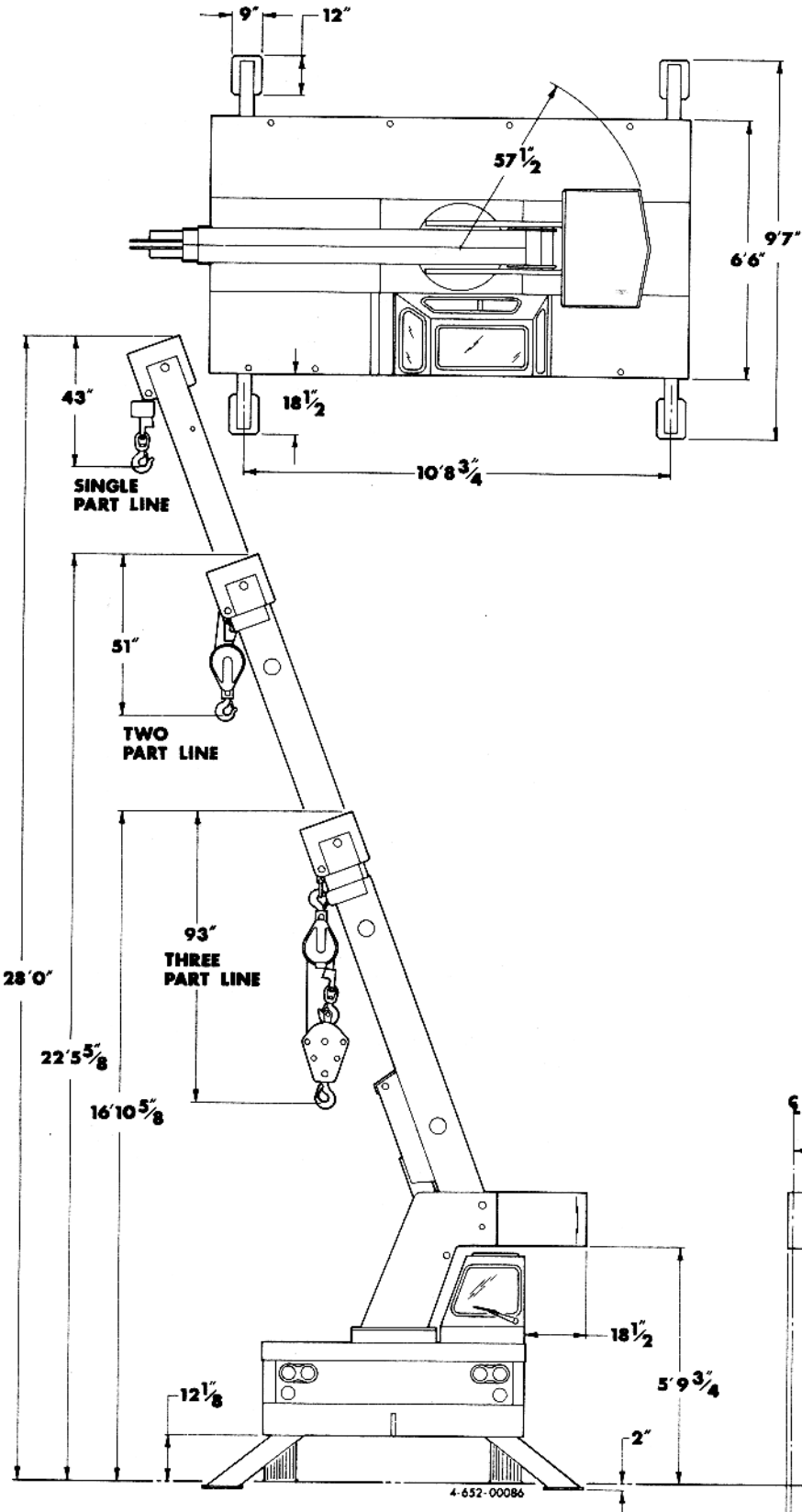

General:

Length:	
Overall	14' 0"
Chassis	11' 11"
Width:	6' 6"
Height:	
Overall	7' 2"
Deck	3' 4"
Wheelbase	6' 6 1/2"
Ground Clearance:	
Chassis	12 1/8"
Minimum (Rear Axle)	6 1/2"
Angle of Approach	26°
Angle of Departure	26°
Turning Radius CL of outside steering wheel)	14' 9"
Weight	13,700 lbs.
Road Speed (3rd Gear Fwd. - Calculated)	20 MPH
Aisle Width for 90° Turn	10' 3"
Drawbar Pull	6,714 lbs.
Outriggers:	
Spread	9' 7"
Penetration	2"
Boom:	
Rotation	Continuous
Elevation	0° to 70°
Extension	12' Hydraulic
Sheave Height (Nominal - w/o Boom Extension)	28' 0"
Sheave Height (Nominal - w/10' Boom Extension)	37' 0"
Horizontal Reach (w/o Boom Extension)	20' 2"
Horizontal Reach (w/10' Boom Extension)	30' 2"

