



## TRANSPORTATION SPECS - All Terrain Cranes

### DEMAG MODEL AC 615 - 250 TON CAPACITY

<u>COMPONENT WEIGHTS</u>		<u>LBS.</u>	<u>KGS.</u>	<u>JIB</u>	<u>O.D 59" X 50"</u>	<u>LBS.</u>	<u>KGS.</u>
Complete Crane (incl. 125 T block, ball & max. cwt.)		296,375	134 472	Fixed Fly	39' – 59' – 79' – 108'		
				Luffing Fly	59'–79'-108'-138'– 167'		
Carrier c/w Outriggers	(1)	109,000	49 456	<b><u>JIB COMPONENT WEIGHTS</u></b>			
Carrier w/o Outriggers	(2)	95,500	43 330	Butt 3.4M	11'2"	1,445	656
Carrier (excl. rear outriggers)	(3)	101,500	46 053	Insert 6M (2)	19'8"	1,630	740
Boom c/w Trailer		76,980	34 927	Insert 6M c/w mast bearing	19'8"	1,680	762
Counterweight – Min.		26,500	12 024	Insert 9M (3)	29'6"	1,705	774
Counterweight – Max.		132,000	59 892	Tip 9.5M	31'2"	2,470	1 121
Certificate Weight			27 200	Mast 10M	32'10"	2,110	957
<u>ADDITIONAL INFORMATION</u>				<u>COUNTERWEIGHT</u>		<u>LBS.</u>	<u>KGS.</u>
125 Ton Block		2,700	1 225	Basic Slab		11,000	4 991
40 Ton Block		1,700	772	Basic Slab		15,000	6 806
12.5 Ton Ball		775	352	Basic Slab (2) ea.		31,000	14 065
Outriggers – Rear (2)		7,500	3 403	Auxiliary Slab (2) ea.		22,000	9 982
Outriggers – Front (2)		6,000	2 723				
Boom		51,900	23 548				
Main Load Line (24 mm x 320 M)		1,984	900				
Auxiliary Load Line (24 mm x 220 M)		1,364	619				

# STERLING CRANE

<u>TRANSPORTATION**</u>		<u>All Provinces / All Seasons</u>		<u>No.</u>	<u>Trailer</u>
			Boom 51,900 lb.	1	Special Tridem
Average Driving Speed		45 km/hr	0 lb. cwt. & misc.	1	Tandem
<b><u>Alberta and Saskatchewan</u></b>	<u>Weight</u>	<u>Trailer</u>	26,500 lb. cwt. & misc.	1	Tandem
• Spring	(1)	Ext 48 wh c/w pilot	57,000 lb. cwt. & misc.	1	S/B Train
• Summer and Winter	(1)	Drive c/w permit & prior approval	88,000 lb. cwt. & misc.	2	Tridem
			132,000 lb. cwt. & misc.	1	S/B Train
				+	1
					Tridem
<b><u>British Columbia</u></b>					
• Spring	(2)	Light weight 8-axle			
• Summer & Winter	(3)	Drive c/w permit & prior approval			

\*\* Block, ball, counterweight and jib are always removed and hauled separately. Trailer types and numbers dependant on amount of counterweight and/or jib required.

# STERLING CRANE

## DIMENSIONS

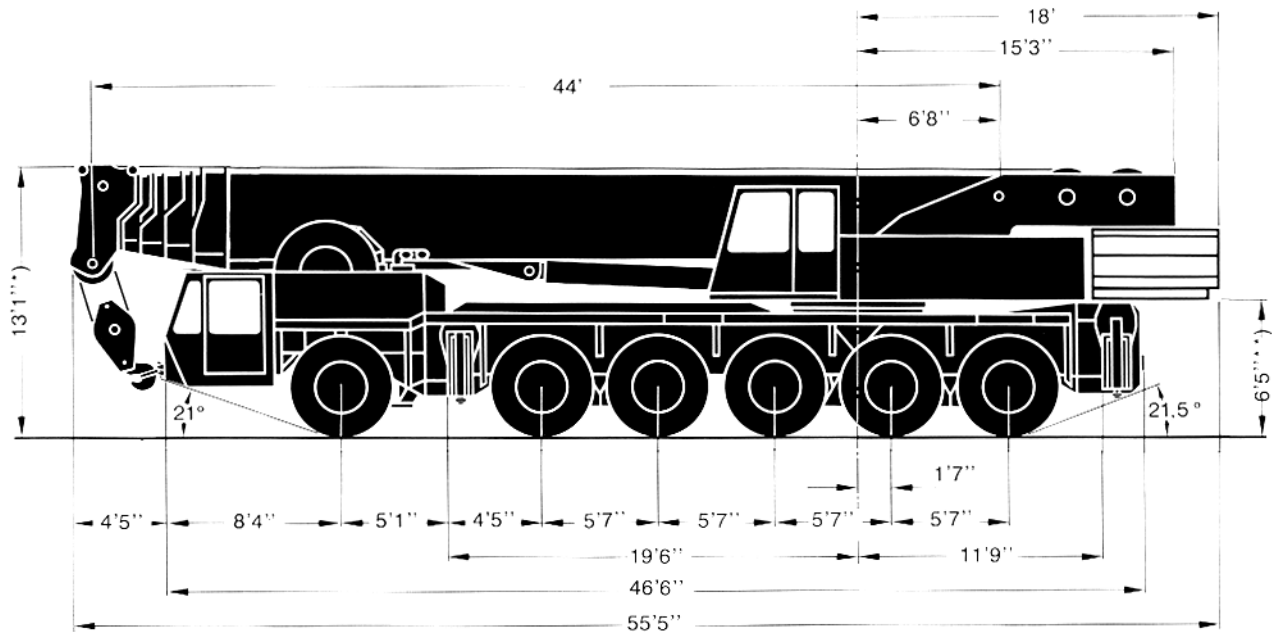

\*) with 14.00 tires and quick disconnect: 13' 5"

\*\*) with 14.00 tires and quick disconnect: 7'

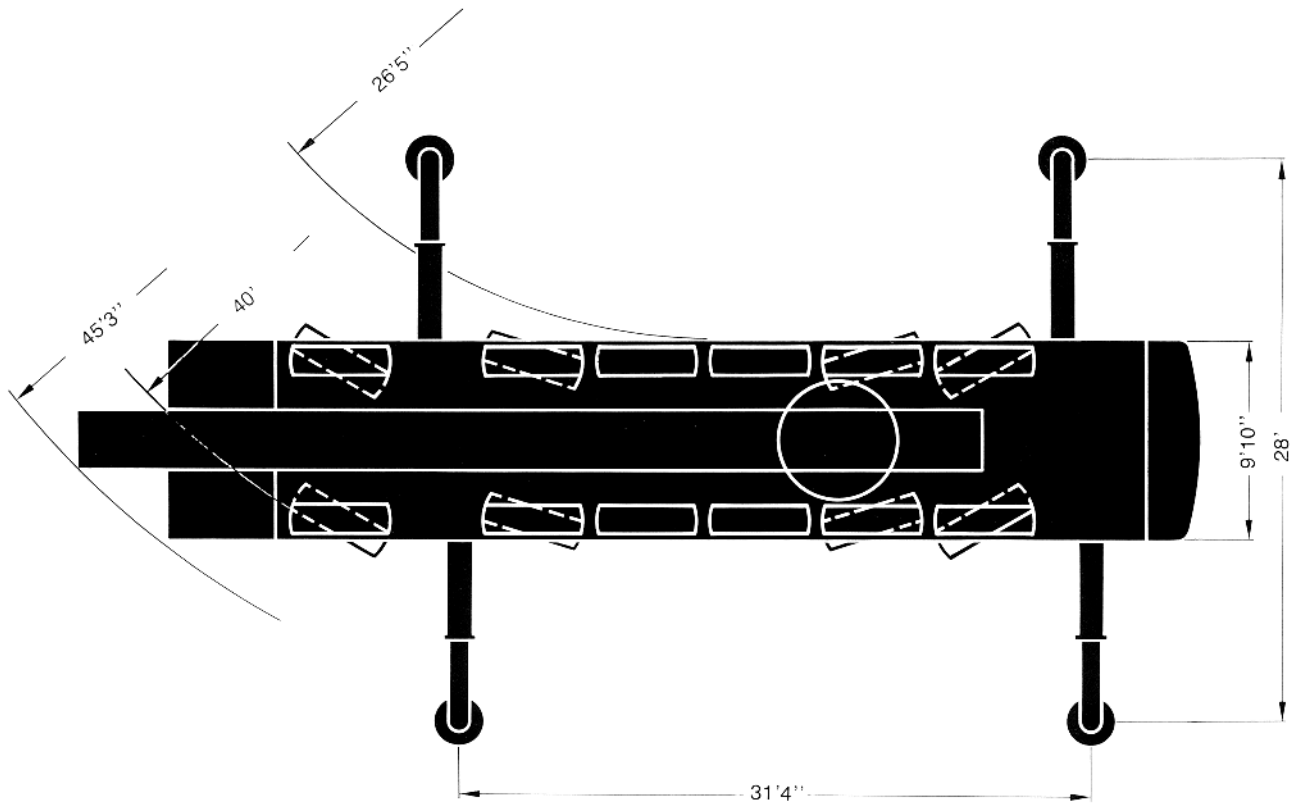

# STERLING CRANE

## DEMAG AC 615 CONFIGURATION

Unit	Main CWT	Luffing Jib 88,000 CWT 83° boom elevation	Fixed Fly Jib	Tele Jib	Super Lift	Intermediate Outrigger Chart
250-6-337 s/n 98038	132,000	√	√		N/A	

Unit	Quick Disconnect	Rooster Sheave	Single Sheave Block	Three Sheave Block	Double J Block	Headache Ball	Notes
250-6-337 s/n 98038	√		√ 40 ton		√ 5 sheave 125 ton	√	