

# STERLING CRANE



## TRANSPORTATION SPECS - Boom Trucks

### MANITEX MODEL 38100S - 38 TON CAPACITY

#### COMPONENT WEIGHTS

	<u>LBS.</u>	<u>KGS.</u>
Complete Crane c/w Jib, Counterweight and Block	54,520	24 730

#### ADDITIONAL INFORMATION

Block 25 Ton 2 Sheave	330	150
Ball 7.5 Ton	172	78
Jib Telescoping 30.5' – 55'	1,720	780
Tire Size Fronts 445/65R22.5 Rears 11R22.5		
Deck Size: N/A		

# STERLING CRANE

## M38100S OUTLINE DIMENSIONS

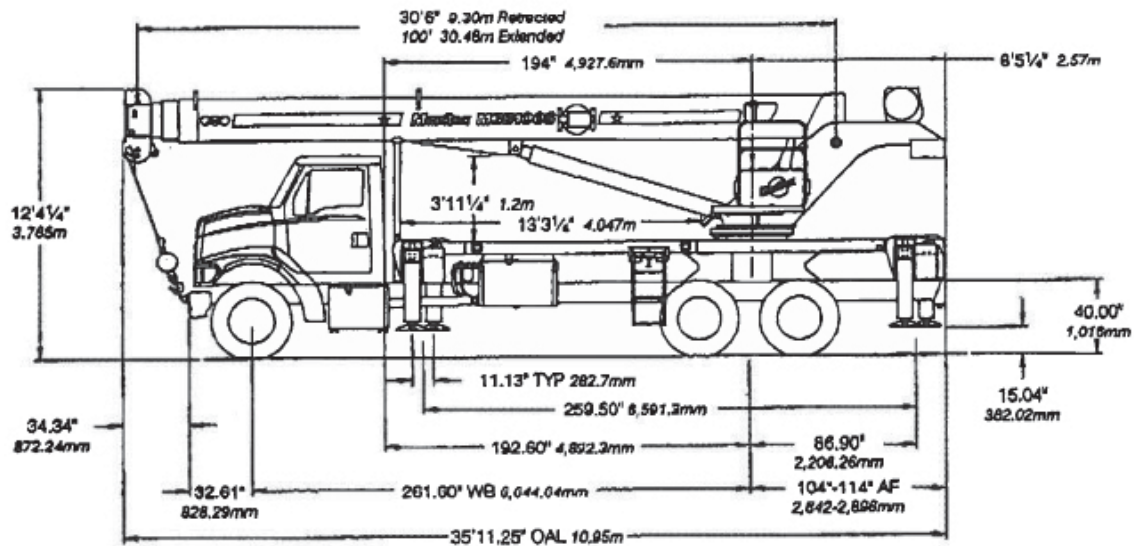

*These dimensions and chassis data are general, not for Engineering. Some dimensions depend on truck selection.*

### TRUCK CHASSIS DATA

#### Recommended Requirements for M38100S

Some crane configurations and options may increase requirements. Trucks with higher horsepower or longer wheelbases may also increase requirements. Consult factory for exact truck specifications. Confirm truck suitability prior to ordering.

Wheelbase (WB) .....	261.60 in .....	6,644mm
Cab to Axle (CA) .....	192.60 in .....	4,892.3mm
After Frame (AF) .....	104-114 in .....	2,641.6-2,896.6mm
Frame Section Modulus .....	110,000 psi .....	758,422 kPa
	25.0 in <sup>3</sup> .....	410cc
Front Axle Gross Weight Rating .....	18,000 lb .....	8,165 kg
Rear Axle Gross Weight Rating .....	38,000 lb .....	17,237 kg
Minimum Truck Axle Weight - Front* .....	8,000 lb .....	3,629 kg
Minimum Truck Axle Weight - Rear* .....	8,300 lb .....	3,765 kg
Nominal Frame Width .....	34 in .....	864mm

\*Minimum chassis weight is required to meet 85% stability requirements.