



TRANSPORTATION SPECS - Hydraulic Truck Cranes

LINK-BELT MODEL HTC-8660 - 60 TON CAPACITY

<u>COMPONENT WEIGHTS</u>	<u>LBS.</u>	<u>KGS.</u>
Complete Crane w/o Dolly (incl. block, ball & jib)	86,200	39 100*
Main Unit	76,965	34 920
Counterweight (2 @ 3000 lbs)	6,000	2 722
Certificate Weight c/w Dolly		45 000
* Actual Scaled Weight		
 <u>ADDITIONAL INFORMATION</u>		
40 Ton Block	720	326
8.5 Ton Ball	360	163
34' - 56' Fly Jib	2,134	968
Boom Dolly	8,465	3 840
Main Load Line (3/4" x 600')	624	284
Auxiliary Hoist Line (3/4" x 600')	624	284
 <u>TRANSPORTATION</u>		
Average Driving Speed		50 km/hr
 <u>Alberta</u>		
• All Seasons	Drive	Trailer Tandem Dolly
 <u>British Columbia</u>		
• Normally	Drive	No Dolly
• Road Ban Period Counterweight on Crane	Drive	Dolly
 <u>Saskatchewan**</u>		
• Normally	Drive	Dolly
• Road Ban Period	Drive	Restricted Travel on Some Secondary Roads
**Yearly Permit		

STERLING CRANE

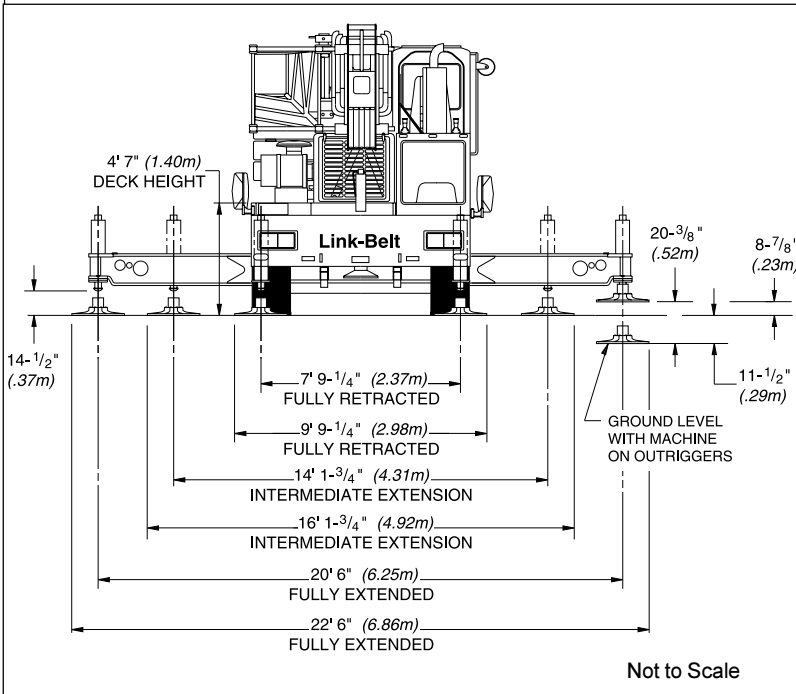
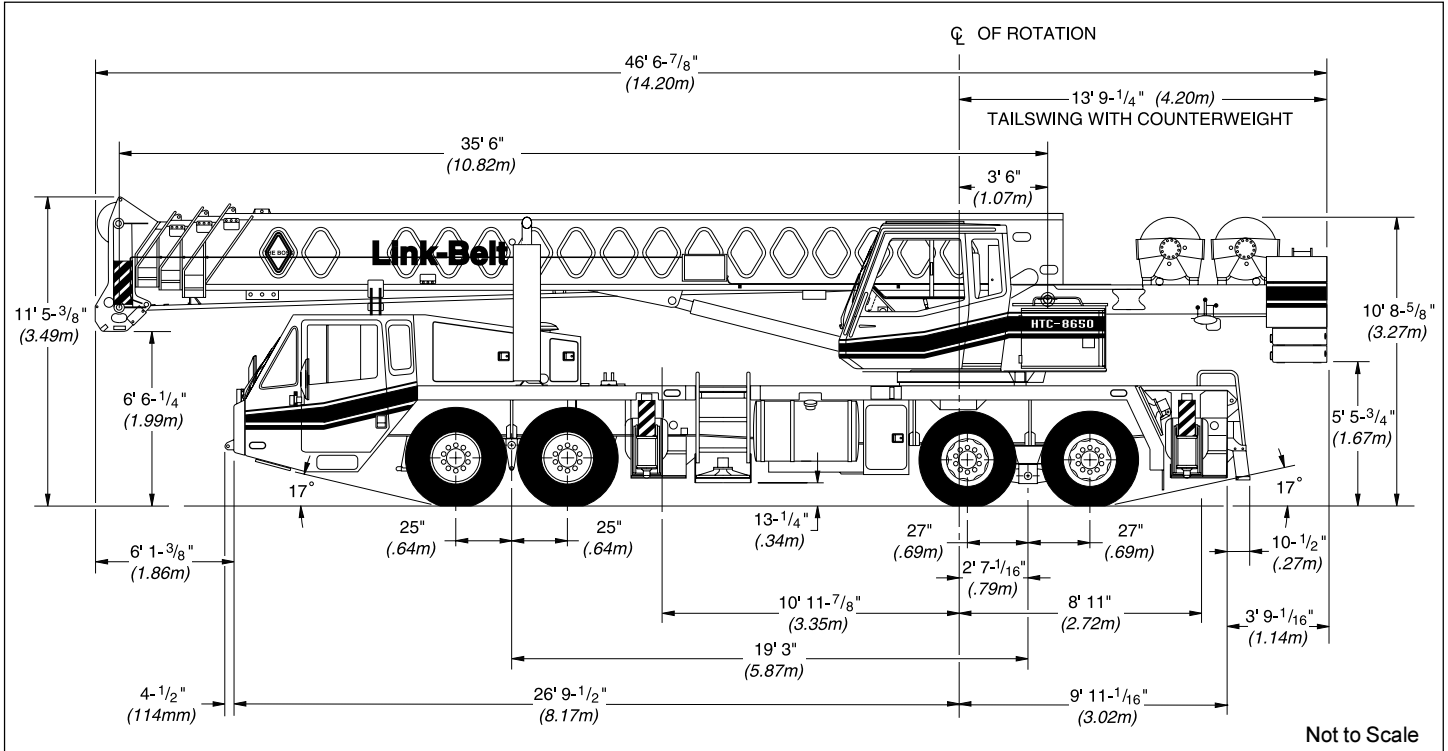

General Dimensions	feet	meters
Turning radius - wall to wall	45' 10"	13.97
Turning radius (curb to curb)	38' 10"	11.84
Ground clearance	13-1/4"	.34
Tailswing	13' 9-1/4"	4.20