



## TRANSPORTATION SPECS - Hydraulic Truck Cranes

### LINK-BELT MODEL HTC-8670 - 70 TON CAPACITY

#### COMPONENT WEIGHTS

		<u>LBS.</u>	<u>KGS.</u>
Complete Crane w/o Dolly (incl. block, ball & 36'6" – 61' jib)	(1)	97,200	44 100
Complete Crane c/w 8,000 lb. counterweight	(2)	89,200	40 472
Main Unit		77,470	35 150
Counterweight (3 pieces @ 4000 and 2 @ 2000)		16,000	7 260
Certificate Weight			45 000

#### ADDITIONAL INFORMATION

60 Ton Block		1,109	504
45 Ton Block (3 sheave) – Optional (Colorado Only)		920	417
8.5 Ton Ball		360	163
36'6" – 61' Two Piece Fly		2,248	1 020
Boom Dolly		8,465	3 840
Counterweight: Main c/w Aux. Hoist : Slab (2) Each		5,000 3,000	2 268 1 361
Main Load Line (3/4" x 550')		572	260
Auxiliary Load Line (3/4" x 550')		572	260

#### TRANSPORTATION

Maximum Speed: 60 km/hr  
37.5 mph

#### Alberta & British Columbia

- Normally
- Spring / Road Ban Period

#### Weight

- (1) Drive
- (1) Drive

#### Trailer

- Tandem Dolly c/w 8,000 lb. cwt.
- Tandem Dolly c/w 12,000 lb. cwt.

#### Colorado

- Complete Crane (2) c/w 8,000 lb. counterweight
- 8,000 lb. counterweight c/w miscellaneous

#### Weight

- (2) Drive
- (2) Drive

#### Trailer

- 
- S/A Truck

#### Saskatchewan

- Normally
- Road Ban Period

- (1) Drive
- (1) Drive

- Tandem Dolly c/w 5 pcs. Cwt.
- Restricted travel on some secondary roads

# STERLING CRANE

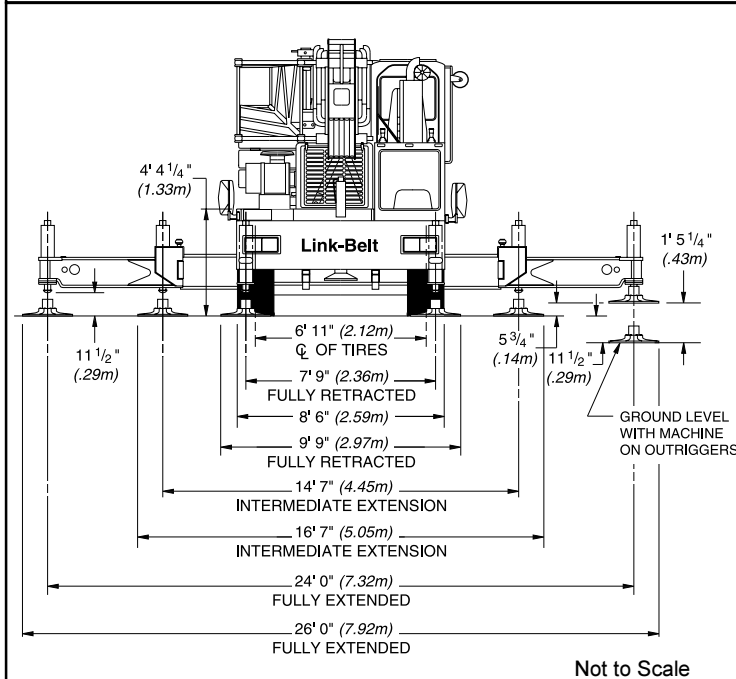
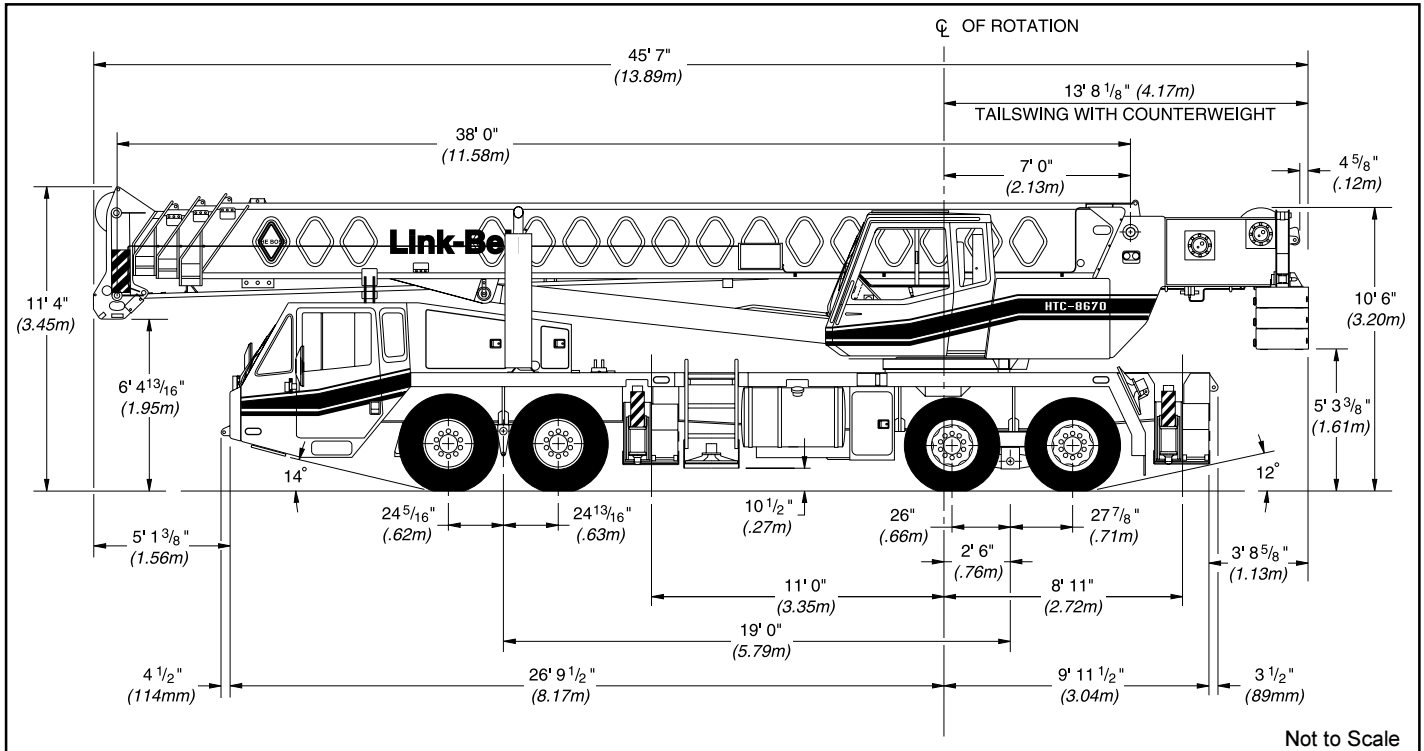

General Dimensions	feet	meters
Turning radius (curb to curb)	38' 10"	11.84
Turning radius (wall to wall)	44' 10-1/2"	13.69
Ground clearance	13-1/4"	.34
Tailswing	13' 9"	4.19