



TRANSPORTATION SPECS - Hydraulic Truck Cranes

LINK-BELT MODEL HTC-8675LB - 75 TON CAPACITY

COMPONENT WEIGHTS

	<u>LBS.</u>	<u>KGS.</u>
Complete Crane w/o Dolly (1) (incl. block, ball & 39'6" – 67' jib)	99,315	45 061
Complete Crane c/w 8,000 lb. counterweight (2)	91,315	41 431
Main Unit	79,446	36 046
Counterweight (3 pieces @ 4000 and 2 @ 2000)	16,000	7 260
Certificate Weight		45 000

ADDITIONAL INFORMATION

60 Ton Block	1,109	504
8.5 Ton Ball	360	163
39'6" – 67' Two Piece Fly	2,380	1 080
Boom Dolly	8,500	3 856
Main Load Line (3/4" x 670')	697	316
Auxiliary Load Line (3/4" x 670')	697	316

TRANSPORTATION

Maximum Speed: 60 km/hr
37.5 mph

Alberta & British Columbia

	<u>Weight</u>	<u>Trailer</u>	<u>Colorado</u>	<u>Weight</u>	<u>Trailer</u>
• Normally	(1) Drive	Tandem Dolly c/w 8,000 lb. cwt.	• Complete Crane (2) c/w 8,000 lb. counterweight	(2) Drive	--
• Spring / Road Ban Period	(1) Drive	Tandem Dolly c/w 12,000 lb. cwt.	• 8,000 lb. counterweight c/w miscellaneous	(2) Drive	S/A Truck

Saskatchewan

• Normally	(1) Drive	Tandem Dolly c/w 5 pcs. Cwt.
• Road Ban Period	(1) Drive	Restricted travel on some secondary roads

STERLING CRANE

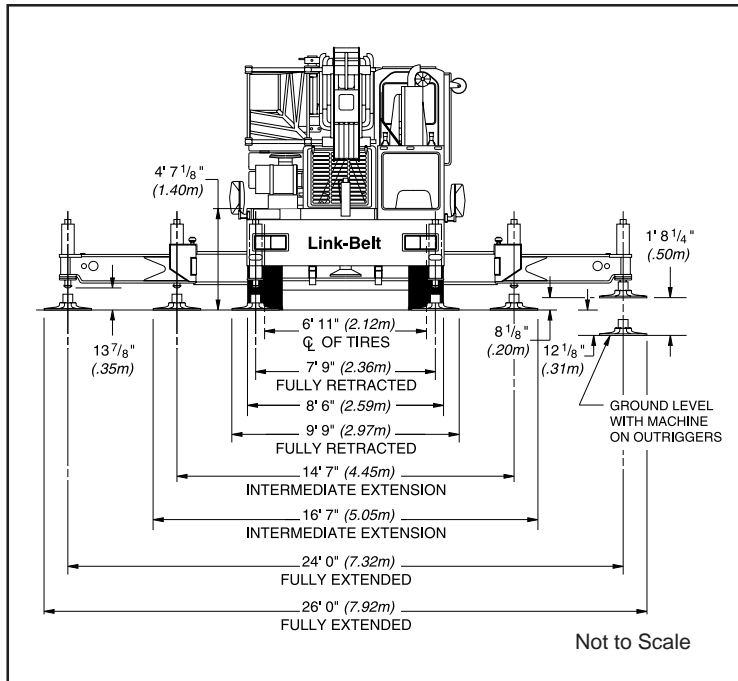
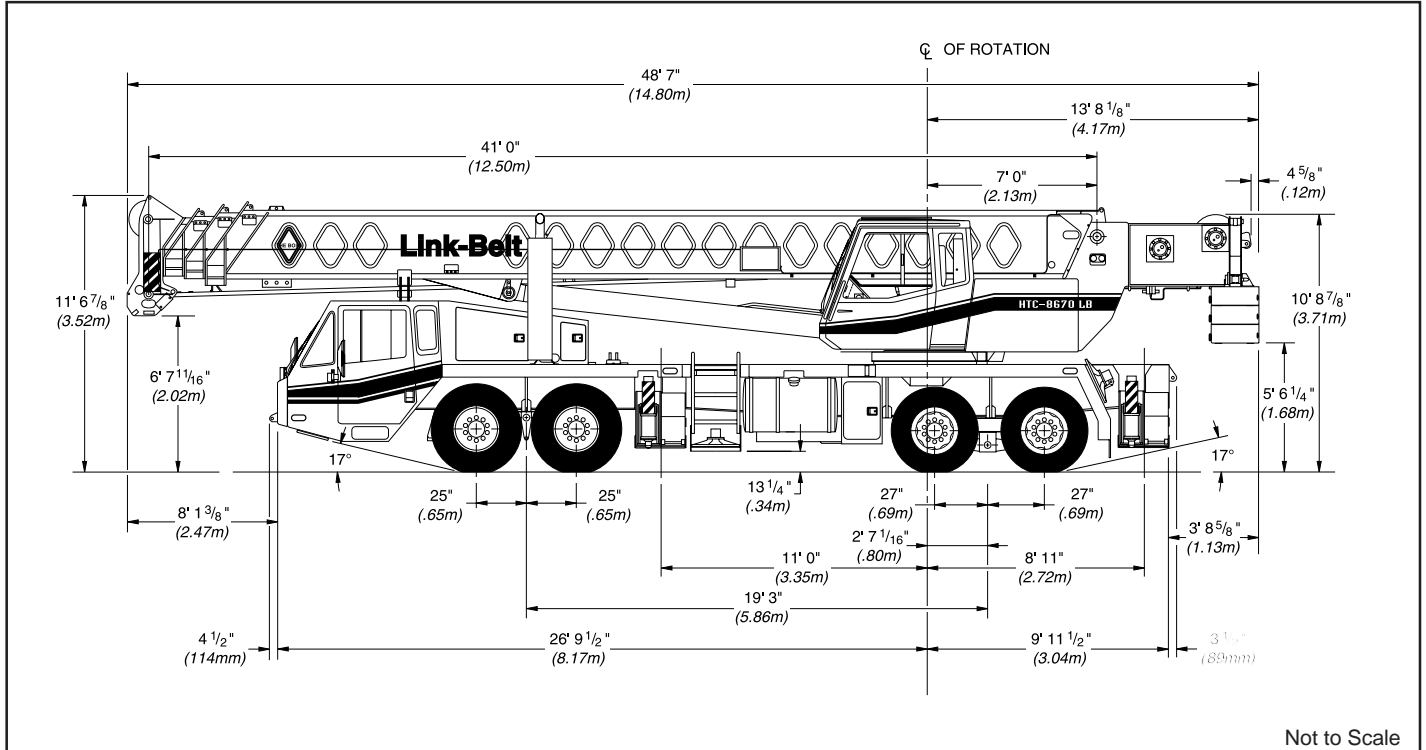

General Dimensions	feet	meters
Turning radius (curb to curb)	41' 7"	12.67
Turning radius (wall to wall)	51' 9"	15.77
Ground clearance	13-1/4"	.34
Tailswing	13' 9"	4.19