



## TRANSPORTATION SPECS - Rough Terrain Cranes

### TADANO MODEL TR-300XL-3 - 30 TON CAPACITY

<u>COMPONENT WEIGHTS</u>		<u>LBS.</u>	<u>KGS.</u>
Complete Crane (incl. block, ball & jib)	(1)	59,200	26 860

#### ADDITIONAL INFORMATION

30 Ton Block		600	272
4.4 Ton Ball		220	100
24'6" Jib		840	380
Main Load Line (16 mm x 185 m)		436	198
Auxiliary Hoist Line (16 mm x 85 m)		200	91

#### TRANSPORTATION

##### Alberta and Saskatchewan

	<u>Weight</u>	<u>Trailer</u>
• Spring	(1)	Light Weight Tri-Axle
• Summer & Winter	(1)	Tri-Axle

##### British Columbia

• Spring		Light Weight Tri-Axle
• Summer & Winter		Tri-Axle

# STERLING CRANE

## DIMENSIONS

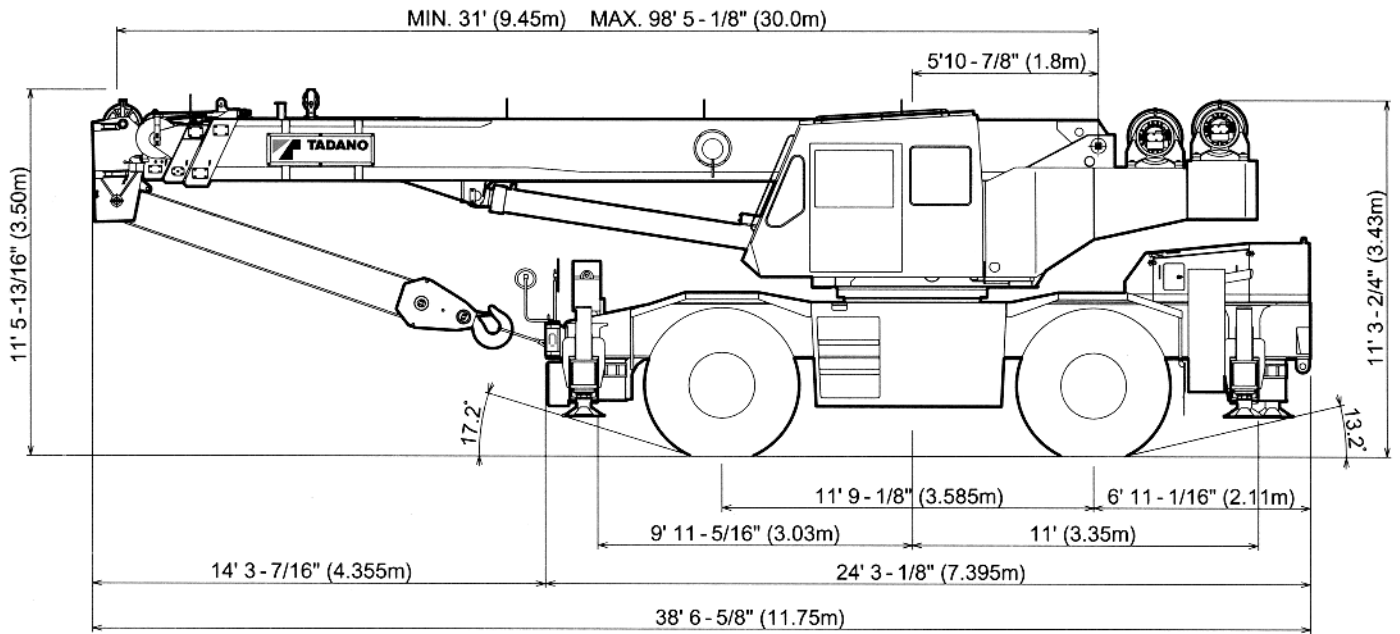

\* Drawing shows Installation of standard main winch and optional auxiliary winch.

### GENERAL DIMENSIONS (20.5 X 25 Tires)

	Feet	Meters
Turning Radius:		
4 wheel steer	21'	6.4
2 wheel steer	36' 5"	11.1
Tail swing of counterweight	11' 1-7/8"	3.4

