



## LIFTING CHARTS - Crawler Cranes

### DEMAG MODEL CC2400-1 - 440 TON CAPACITY

#### SPECIFICATIONS

##### WORKING SPEEDS (INFINITELY VARIABLE)

Mechanisms	Speeds <sup>1)</sup>	Single line pull	Length of hoist rope
Hoist I	max. 492 ft / min	33,709 lb / 29,889 lb <sup>2)</sup>	3346 ft
Hoist II	max. 426 ft / min	33,709 lb / 31,688 lb <sup>2)</sup>	2296 ft
Boom derricking	max. 456 ft / min		
Boom hoist	max. 177 ft / min		
Jib luffing	max. 361 ft / min		
Slewing (RPM)	1.4		

1) top layer

2) without / with reeving effect considered

#### BASIC CRANE DIMENSIONS

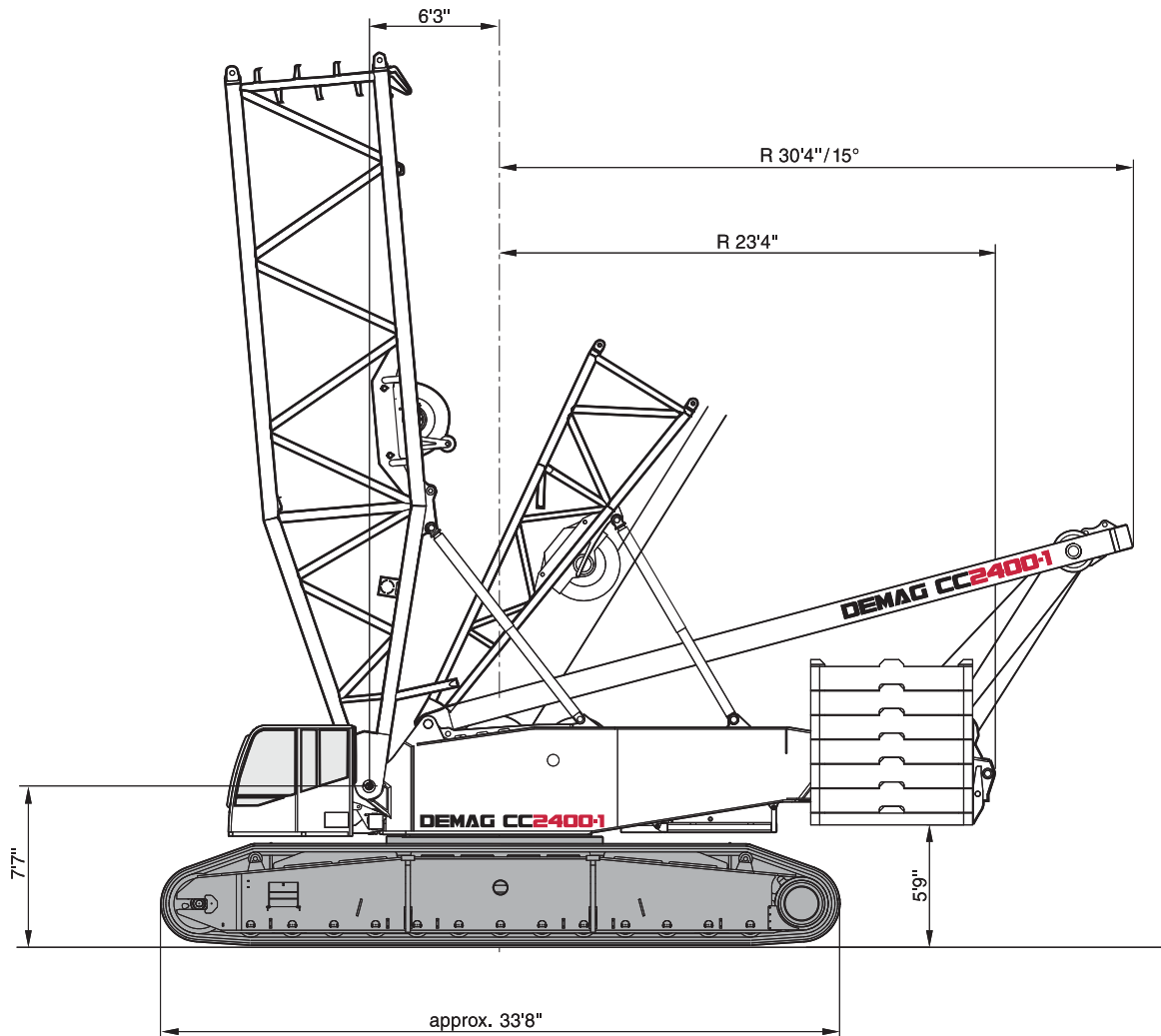

# STERLING CRANE

## SPECIFICATIONS

### CARRIER PERFORMANCE

Travel speed

max. 1.24 mph

### HOOK BLOCKS

Type	Possible load	Number of sheaves	Number of lines	Weight	„D“
2 x 200	881,850 lb	2 x 7	2 x 15	14,110 – 16,315 lb	15'2"
	440,925 lb	7	15	9,921 – 11,024 lb	16'5"
2 x 160	696,661 lb	2 x 5	2 x 11	9,480 – 13,890 lb	15'2"
	687,843 lb	11	23	9,701 – 14,110 lb	15'2"
	348,331 lb	15	11	7,055 – 9,260 lb	16'5"
100	220,463 lb	13	7	4,410 – 17,717 lb	12'2"
50	199,209 lb	11	3	3,748 lb	12'2"
15	133,070 lb	1	1	1,985 lb	11'2"

