

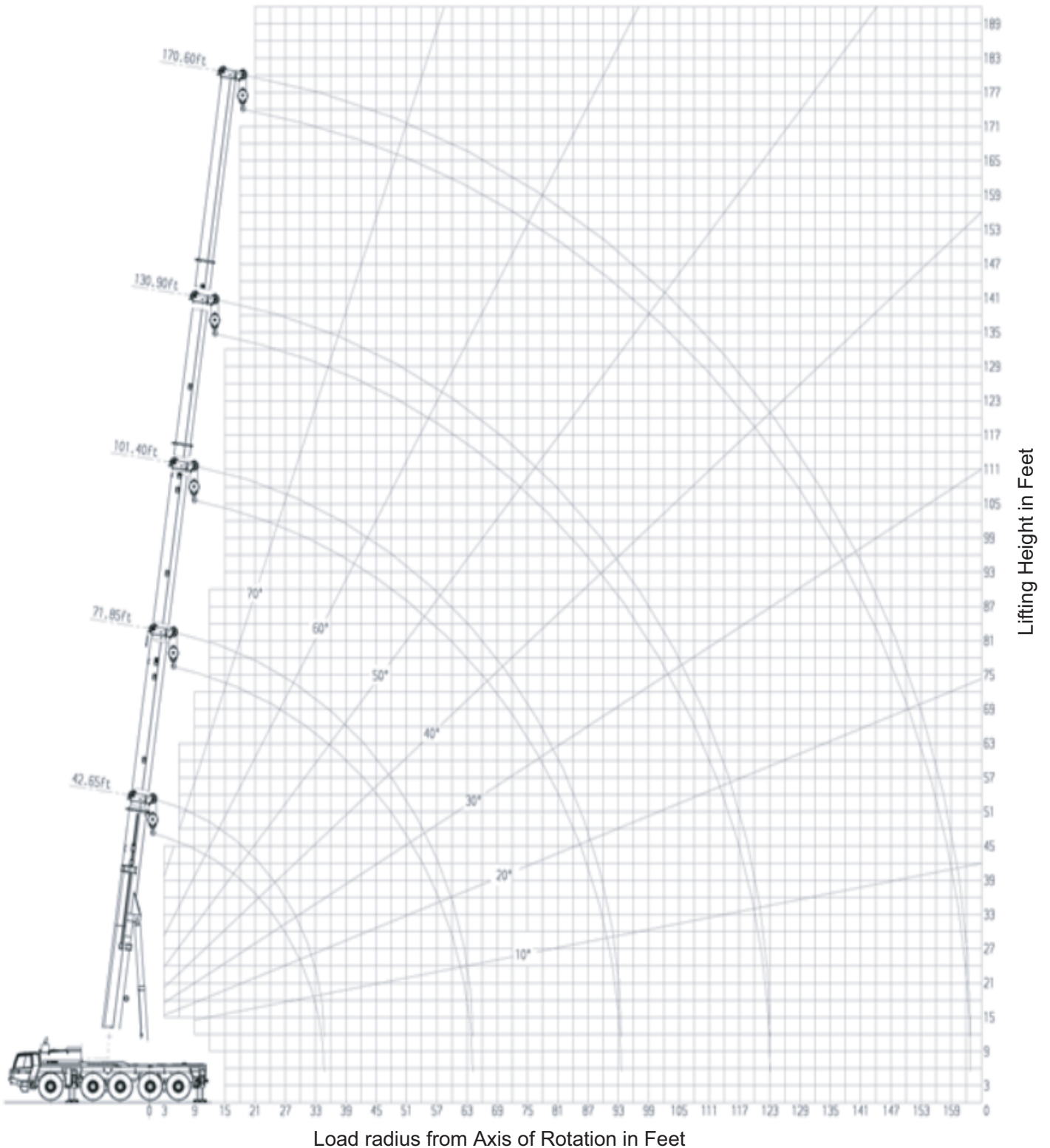

LIFTING CHARTS - All Terrain Cranes

TADANO MODEL ATF110G-5 - 130 TON CAPACITY

WORKING RANGE CHART



NOTE: Boom and jib geometry shown are for unloaded condition and machine standing level on firm supporting surface. Boom deflection and subsequent radius and boom angle change must be accounted for when applying load to hook.

STERLING CRANE

Load rating charts

Counterweight 77,160 lbs

Work. Radius (ft)	Lifting capacities in 1,000 lbs according per SAE J765 on telescopic boom On outriggers, 360° working area Outrigger base 24.61 ft													Work. Radius (ft)					
	Boom length (ft)																		
	42.7 °	57.1 °	57.1 °	57.1 °	71.9 °	71.9 °	71.9 °	71.9 °	86.6 °	86.6 °	86.6 °	86.6 °							
10	69	260.0*	228.0*	75	194.0	75	114.0	75	104.0	79	162.0	79	114.0	79	104.0	79	96.6	10	
12	66	234.0*	206.0	73	192.0	73	114.0	73	104.0	77	158.0	77	114.0	77	104.0	77	91.8	12	
14	63	215.0	187.5	71	183.5	71	114.0	71	104.0	75	151.5	75	114.0	75	104.0	75	86.8	14	
16	60	193.5	171.5	68	170.0	68	114.0	68	104.0	73	141.0	73	114.0	73	104.0	73	81.7	16	
18	57	173.0	158.5	67	157.0	67	114.0	67	101.5	72	131.5	72	114.0	72	104.0	72	76.5	18	
20	53	154.5	146.0	65	144.5	65	114.0	65	98.2	71	122.5	71	114.0	71	103.5	71	71.5	20	
25	44	122.5	121.5	59	120.0	59	114.0	59	87.9	66	106.5	66	114.0	66	98.4	66	61.4	25	
30	30	100.5	100.5	52	98.5	52	102.0	52	78.5	62	92.8	62	102.0	62	90.4	62	54.0	30	
35				45	82.9	45	85.5	45	70.8	57	80.7	57	86.2	57	81.3	57	47.8	35	
40				37	70.4	37	73.7	37	64.4	51	69.1	51	73.7	51	72.1	51	42.9	40	
45				25	57.1	25	60.3	25	59.7	46	56.0	46	60.6	46	62.1	46	38.9	45	
50										39	47.0	39	51.6	39	53.5	39	35.5	50	
55										32	40.0	32	44.5	32	46.4	32	32.8	55	
60										23	34.2	23	38.3	23	40.3	23	30.4	60	
65																	36	65	
70																	29	70	
75																	22	75	
80																		22	80
85																			85
90																			90
95																			95
100																			100
110																			110
120																			120
130																			130
140																			140
150																			150
Telescoping sequence %																			
Tel. 1	0		46	0	0	0	92	46	0	0	92	46	0	0	Tel. 1				
Tel. 2	0	0	0	0	0	0	46	0	0	46	46	46	0	Tel. 2					
Tel. 3	0	0	46	0	0	0	46	0	46	0	46	46	46	Tel. 3					
Tel. 4	0	0	0	46	0	0	46	92	0	0	46	92	46	Tel. 4					

1) Over rear with superstructure pin engaged
*With additional lifting equipment.

Operation and maintenance of this machine must be in compliance with the information provided in the "Operation and Maintenance Manual" supplied with this machine.

Counterweight 63,490 lbs

Work. Radius (ft)	Lifting capacities in 1,000 lbs according per SAE J765 on telescopic boom On outriggers, 360° working area Outrigger base 24.61 ft													Work. Radius (ft)					
	Boom length (ft)																		
	42.7 °	57.1 °	57.1 °	57.1 °	71.9 °	71.9 °	71.9 °	71.9 °	86.6 °	86.6 °	86.6 °	86.6 °							
10	69	260.0*	228.0*	75	194.0	75	114.0	75	104.0	79	162.0	79	114.0	79	104.0	79	96.6	10	
12	66	234.0*	205.5	73	192.0	73	114.0	73	104.0	77	158.0	77	114.0	77	104.0	77	91.8	12	
14	63	211.5	187.0	71	183.0	71	114.0	71	104.0	75	151.5	75	114.0	75	104.0	75	86.8	14	
16	60	187.0	171.0	68	169.5	68	114.0	68	104.0	73	141.0	73	114.0	73	104.0	73	81.7	16	
18	57	167.0	158.0	67	156.5	67	114.0	67	101.5	72	131.5	72	114.0	72	104.0	72	76.5	18	
20	53	149.0	145.5	65	144.0	65	114.0	65	98.2	71	122.5	71	114.0	71	103.5	71	71.5	20	
25	44	118.0	118.0	59	116.0	59	113.5	59	87.9	66	106.5	66	113.5	66	98.4	66	61.4	25	
30	30	96.7	96.7	52	95.0	52	98.3	52	78.5	62	92.8	62	98.3	62	90.4	62	54.0	30	
35				45	76.6	45	80.2	45	70.8	57	75.5	57	80.4	57	81.3	57	47.8	35	
40				37	61.5	37	65.2	37	63.9	51	60.4	51	65.7	51	67.8	51	42.9	40	
45				25	51.1	25	54.5	25	55.2	46	50.0	46	54.9	46	56.9	46	38.9	45	
50										39	42.0	39	46.6	39	48.7	39	35.5	50	
55										32	35.6	32	40.1	32	42.1	32	32.8	55	
60										23	30.0	23	34.7	23	36.4	23	30.4	60	
65																	36	65	
70																	29	70	
75																	22	75	
80																		22	80
85																			85
90																			90
95																			95
100																			100
110																			110
120																			120
130																			130
140																			140
150																			150
Telescoping sequence %																			
Tel. 1	0		46	0	0	0	92	46	0	0	92	46	0	0	Tel. 1				
Tel. 2	0	0	0	0	0	0	46	0	0	46	46	46	46	0	Tel. 2				
Tel. 3	0	0	46	0	0	0	46	0	46	0	46	46	46	46	Tel. 3				
Tel. 4	0	0	0	46	0	0	46	92	0	0	46	92	46	92	Tel. 4				

1) Over rear with superstructure pin engaged
*With additional lifting equipment.

Operation and maintenance of this machine must be in compliance with the information provided in the "Operation and Maintenance Manual" supplied with this machine.

STERLING CRANE

Load rating charts

Counterweight 77,160 lbs

Lifting capacities in 1,000 lbs according per SAE J765 on telescopic boom On outriggers, 360° working area Outrigger base 16.40 ft																	
Work. Radius (ft)	Boom length (ft)													Work. Radius (ft)			
	42.7	57.1	57.1	57.1	71.9	71.9	71.9	71.9	86.6	86.6	86.6	86.6					
10	69	203.5	75	193.0	75	114.0	75	104.0	79	162.0	79	114.0	79	104.0	79	96.6	10
12	66	181.0	73	179.5	73	114.0	73	104.0	77	158.0	77	114.0	77	104.0	77	91.8	12
14	63	162.5	71	161.5	71	114.0	71	104.0	75	151.5	75	114.0	75	104.0	75	86.8	14
16	60	147.5	68	145.5	68	114.0	68	104.0	73	141.0	73	114.0	73	104.0	73	81.7	16
18	57	135.0	67	133.0	67	114.0	67	101.5	72	131.0	72	114.0	72	104.0	72	76.5	18
20	53	123.5	65	122.0	65	113.5	65	98.2	71	121.0	71	113.5	71	103.5	71	71.5	20
25	44	96.6	59	94.9	59	98.5	59	87.9	66	92.1	66	97.3	66	95.6	66	61.4	25
30	30	71.6	52	69.6	52	73.7	52	74.3	62	68.5	62	74.0	62	76.4	62	54.0	30
35			45	54.1	45	58.0	45	59.1	57	53.1	57	58.3	57	60.5	57	47.8	35
40			37	43.8	37	47.3	37	48.4	51	42.7	51	47.5	51	49.7	51	42.9	40
45			25	36.1	25	39.4	25	40.5	46	34.9	46	39.6	46	41.6	46	38.9	45
50									39	29.0	39	33.5	39	35.5	39	35.0	50
55									32	24.1	32	28.5	32	30.5	32	30.9	55
60									23	19.9	23	24.3	23	26.3	23	26.5	60
65																	65
70																	70
75																	75
80																	80
85																	85
90																	90
95																	95
100																	100
110																	110
120																	120
130																	130
140																	140
150																	150
Telescoping sequence %																	
Tel. 1	0	46	0	0	92	46	0	0	92	46	0	0	92	46	0	0	Tel. 1
Tel. 2	0	0	0	0	0	46	0	0	46	46	46	46	46	46	0	0	Tel. 2
Tel. 3	0	0	46	0	0	0	46	0	0	46	46	46	46	46	46	46	Tel. 3
Tel. 4	0	0	0	46	0	0	46	92	0	0	46	92	0	0	46	92	Tel. 4

Operation and maintenance of this machine must be in compliance with the information provided in the "Operation and Maintenance Manual" supplied with this machine.

Counterweight 63,490 lbs

Lifting capacities in 1,000 lbs according per SAE J765 on telescopic boom On outriggers, 360° working area Outrigger base 16.40 ft																	
Work. Radius (ft)	Boom length (ft)													Work. Radius (ft)			
	42.7	57.1	57.1	57.1	71.9	71.9	71.9	71.9	86.6	86.6	86.6	86.6					
10	69	201.0	75	193.0	75	114.0	75	104.0	79	162.0	79	114.0	79	104.0	79	96.6	10
12	66	178.5	73	177.0	73	114.0	73	104.0	77	158.0	77	114.0	77	104.0	77	91.8	12
14	63	160.5	71	159.0	71	114.0	71	104.0	75	151.5	75	114.0	75	104.0	75	86.8	14
16	60	145.0	68	143.5	68	114.0	68	104.0	73	141.0	73	114.0	73	104.0	73	81.7	16
18	57	133.0	67	131.5	67	114.0	67	101.5	72	122.5	72	114.0	72	104.0	72	76.5	18
20	53	120.5	65	119.0	65	112.5	65	98.2	71	103.5	71	111.5	71	103.5	71	71.5	20
25	44	85.1	59	82.6	59	86.8	59	85.6	66	77.2	66	83.4	66	88.3	66	61.4	25
30	30	62.5	52	60.7	52	64.5	52	66.5	62	59.4	62	64.9	62	67.3	62	54.0	30
35			45	46.9	45	50.5	45	51.8	57	45.7	57	50.9	57	53.1	57	47.8	35
40			37	37.5	37	41.0	37	42.1	51	36.4	51	41.2	51	43.4	51	42.6	40
45			25	30.6	25	33.9	25	35.0	46	29.5	46	34.2	46	36.2	46	36.4	45
50									39	24.3	39	28.7	39	30.7	39	31.0	50
55									32	20.0	32	24.3	32	26.3	32	26.6	55
60									23	16.3	23	20.4	23	22.4	23	22.9	60
65																	65
70																	70
75																	75
80																	80
85																	85
90																	90
95																	95
100																	100
110																	110
120																	120
130																	130
140																	140
150																	150
Telescoping sequence %																	
Tel. 1	0	46	0	0	92	46	0	0	92	46	0	0	92	46	0	0	Tel. 1
Tel. 2	0	0	0	0	0	46	0	0	46	46	46	46	46	46	0	0	Tel. 2
Tel. 3	0	0	46	0	0	0	46	0	0	46	46	46	46	46	46	46	Tel. 3
Tel. 4	0	0	0	46	0	0	46	92	0	0	46	92	0	0	46	92	Tel. 4

Operation and maintenance of this machine must be in compliance with the information provided in the "Operation and Maintenance Manual" supplied with this machine.

STERLING CRANE

Load rating charts

Counterweight 0 lbs

Work. Radius (ft)	Lifting capacities in 1,000 lbs according per SAE J765 on telescopic boom On outriggers, 360° working area Outrigger base 16.40 ft														Work. Radius (ft)			
	Boom length (ft)																	
	42.7	57.1	57.1	57.1	71.9	71.9	71.9	71.9	71.9	71.9	71.9	71.9	71.9	71.9				
10	69	161.0	75	127.0	75	114.0	75	104.3	79	103.3	79	111.9	79	104.0	79	96.6	10	
12	66	114.0	73	93.4	73	105.0	73	99.3	77	79.0	77	87.4	77	96.7	77	91.8	12	
14	63	86.1	71	72.5	71	78.4	71	80.8	75	62.0	75	70.2	75	73.8	75	78.1	14	
16	60	68.6	68	57.8	68	63.0	68	65.6	73	50.0	73	57.6	73	61.1	73	61.6	16	
18	57	57.1	67	48.1	67	53.1	67	55.4	72	41.9	72	48.8	72	52.1	72	52.8	18	
20	53	46.8	65	39.9	65	44.7	65	46.6	71	34.9	71	41.1	71	44.1	71	45.0	20	
25	44	29.5	59	26.9	59	31.3	59	32.7	66	23.4	66	29.4	66	32.2	66	32.8	25	
30	30	19.6	52	17.7	52	21.6	52	22.9	62	16.0	62	21.7	62	24.3	62	24.7	30	
35			45	11.7	45	15.4	45	16.6	57	10.6	57	15.7	57	18.0	57	18.4	35	
40			37	7.8	37	11.3	37	12.4	51	6.7	51	11.5	51	13.7	51	14.1	40	
45			25	4.8	25	8.1	25	9.2	46	3.6	46	8.3	46	10.5	46	10.8	45	
50												39	5.9	39	8.0	39	8.4	50
55												32	4.0	32	6.0	32	6.3	55
60												23	2.3	23	4.3	23	4.5	60
65																		65
70																		70
75																		75
80																		80
85																		85
90																		90
95																		95
100																		100
110																		110
120																		120
130																		130
140																		140
150																		150
Telescoping sequence %																		
Tel. 1	0		46		0		92		46		0		0		0		Tel. 1	
Tel. 2	0		0		0		0		46		0		0		0		Tel. 2	
Tel. 3	0		0		46		0		0		0		46		0		Tel. 3	
Tel. 4	0		0		0		46		0		0		0		92		Tel. 4	

Operation and maintenance of this machine must be in compliance with the information provided in the "Operation and Maintenance Manual" supplied with this machine.

STERLING CRANE

ATF110G-5 WORKING RANGE CHART

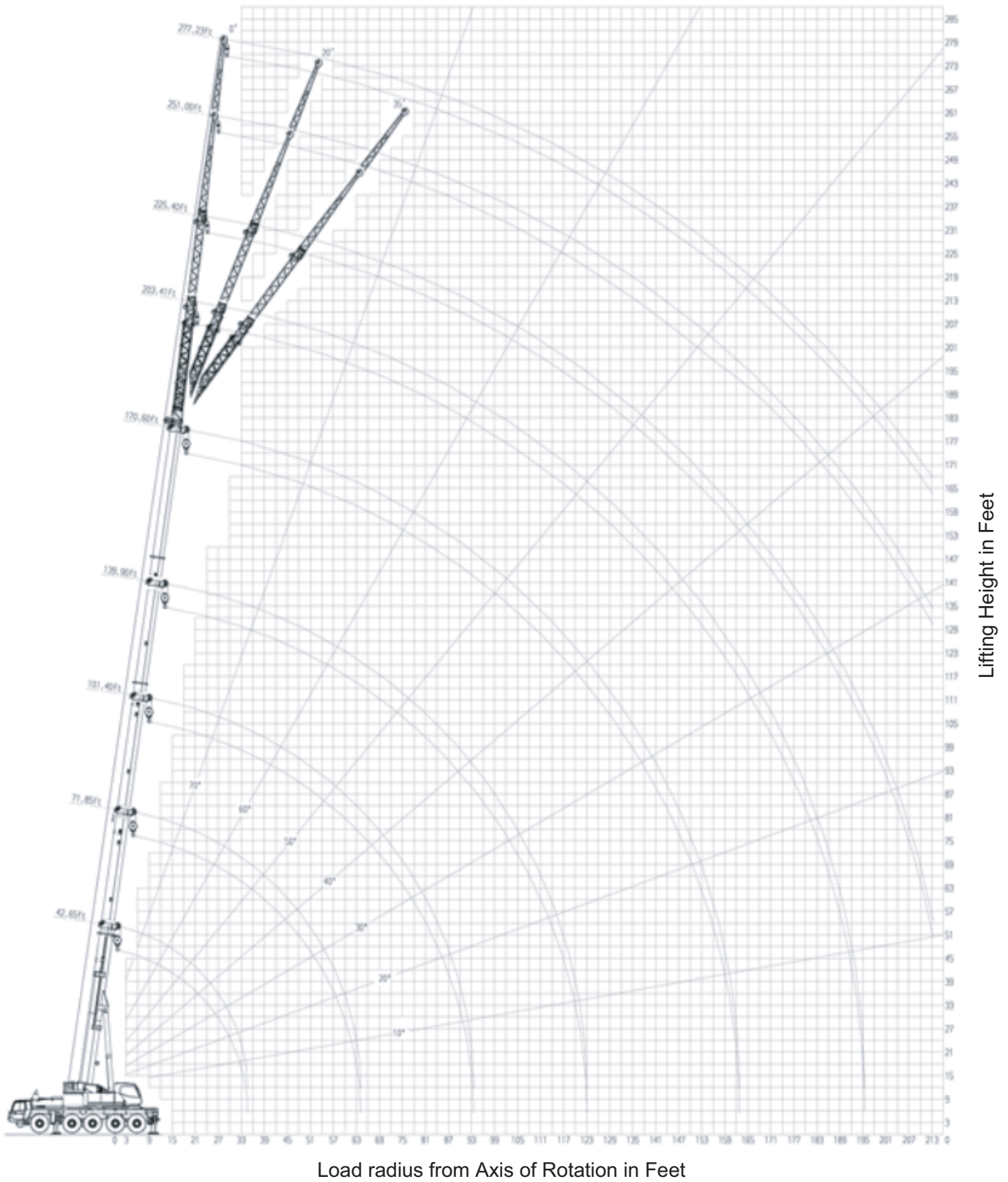

NOTE: Boom and jib geometry shown are for unloaded condition and machine standing level on firm supporting surface. Boom deflection and subsequent radius and boom angle change must be accounted for when applying load to hook.

STERLING CRANE

Load rating charts

Counterweight 77,160 lbs

Working Radius (ft)	Lifting capacities in 1,000 lbs according per SAE J765 on fly jib 31.17 ft / 53.15 ft / 79.07 ft / 98.75 ft												Working Radius (ft)		
	On outriggers, 360° working area														
	Outrigger base 24.61 ft														
	Boom length 42.7 ft to 160.4 ft														
	Fly jib 31.17 ft offset			Fly jib 53.15 ft offset			Fly jib 79.07 ft offset			Fly jib 98.75 ft offset					
	0°	20°	35°	0°	20°	35°	0°	20°	35°	0°	20°	35°			
35	79	17.0												35	
40	78	17.0	81	17.0										40	
45	76	17.0	79	17.0										45	
50	75	17.0	78	16.7			77	12.3		78	7.7			50	
55	74	17.0	76	16.3	78	12.7	76	12.3	80	10.9		77	7.7	55	
60	73	17.0	75	15.9	77	12.3	75	12.3	79	10.9		76	7.7	60	
65	71	17.0	74	15.6	75	11.9	73	12.3	77	10.7		75	7.7	65	
70	70	17.0	73	15.2	74	11.8	72	12.3	76	10.3	79	7.1	74	7.7	70
75	68	16.5	71	14.7	72	11.4	71	12.3	75	10.0	77	7.0	73	7.6	75
80	67	15.8	70	14.2	71	11.1	70	12.3	74	9.6	76	6.8	72	7.4	80
85	65	15.2	68	13.6	69	10.9	68	12.1	72	9.3	75	6.5	71	7.2	85
90	64	14.6	66	13.1	68	10.8	67	11.8	71	8.9	74	6.3	70	7.0	90
95	62	14.0	64	12.6	66	10.6	66	11.5	69	8.5	72	6.2	69	6.7	95
100	61	13.4	63	12.2	65	10.4	65	11.2	68	8.2	71	6.1	68	6.3	100
110	57	12.5	59	11.5	61	10.0	64	10.1	64	7.6	67	5.9	64	5.7	110
120	53	11.5	55	10.8	57	9.6	58	9.3	61	7.2	64	5.7	62	5.1	120
130	49	9.7	52	10.0	53	9.3	55	8.6	58	6.8	60	5.5	59	4.7	130
140	45	7.9	47	8.3	48	8.5	51	7.9	55	6.3	57	5.3	56	4.3	140
150	40	6.4	42	6.6	43	7.0	48	7.3	51	6.1	53	5.2	53	3.9	150
160	34	5.0	36	5.3	36	5.3	44	6.2	47	5.8	49	5.1	50	3.6	160
170	27	3.9	29	3.9	29	3.9	39	5.1	42	5.5	44	5.0	47	3.3	170
180	18	3.0	19	2.9	18	2.6	34	4.3	37	4.5	38	4.5	44	3.1	180
190							28	3.4	31	3.4	30	3.4	40	2.8	190
200							21	2.3	22	2.3	20	1.9	36	2.5	200
210															210
220															220
230															230
240															240
250															250
Telescoping sequence %															
Tel. 1	92												Tel. 1		
Tel. 2	92												Tel. 2		
Tel. 3	92												Tel. 3		
Tel. 4	92												Tel. 4		

Operation and maintenance of this machine must be in compliance with the information provided in the "Operation and Maintenance Manual" supplied with this machine.

Counterweight 77,160 lbs

Working Radius (ft)	Lifting capacities in 1,000 lbs according per SAE J765 on fly jib 31.17 ft / 53.15 ft / 79.07 ft / 98.75 ft												Working Radius (ft)		
	On outriggers, 360° working area														
	Outrigger base 24.61 ft														
	Boom length 43.3 ft to 170.6 ft														
	Fly jib 31.17 ft offset			Fly jib 53.15 ft offset			Fly jib 79.07 ft offset			Fly jib 98.75 ft offset					
	0°	20°	35°	0°	20°	35°	0°	20°	35°	0°	20°	35°			
35	80	14.6												35	
40	79	14.6												40	
45	77	14.6												45	
50	76	14.6	79	14.6		78	10.9							50	
55	75	14.6	77	14.6	79	12.9	77	10.9					79	5.1	55
60	74	14.6	76	14.6	78	12.5	76	10.9	79	9.7			77	7.3	60
65	72	14.6	75	14.6	77	12.2	74	10.9	78	9.7			76	7.3	65
70	71	14.6	74	14.4	76	12.0	73	10.9	77	9.4			75	7.3	70
75	70	14.6	72	14.0	74	11.7	72	10.9	76	9.0	78	6.1	74	7.3	75
80	69	14.3	71	13.5	73	11.3	71	10.9	75	8.6	77	5.9	73	7.2	80
85	67	13.5	69	12.8	71	11.1	69	10.9	73	8.3	76	5.7	72	7.1	85
90	66	12.7	68	12.1	70	10.8	68	10.8	72	8.1	75	5.7	71	7.0	90
95	64	11.9	66	11.4	68	10.6	67	10.4	70	7.8	73	5.5	70	6.8	95
100	63	11.1	65	10.7	67	10.3	66	10.0	69	7.4	72	5.3	69	6.6	100
110	59	9.8	61	9.5	63	9.4	62	8.9	66	7.0	68	5.1	66	5.9	110
120	55	8.7	58	8.4	59	8.4	60	8.0	63	6.4	65	4.9	64	5.4	120
130	52	7.7	54	7.5	56	7.5	57	7.1	60	6.1	62	4.8	61	4.9	130
140	48	6.9	50	6.8	52	6.8	54	6.4	57	5.8	59	4.6	59	4.5	140
150	44	6.1	46	6.1	47	6.1	50	5.7	54	5.5	56	4.5	56	4.1	150
160	39	5.0	41	5.3	42	5.4	47	5.1	50	5.1	52	4.4	53	3.8	160
170	33	3.9	36	4.1	36	4.1	43	4.5	46	4.5	48	4.3	50	3.5	170
180	27	2.9	29	3.0	29	2.9	39	4.0	42	4.2	43	4.0	47	3.3	180
190							34	3.2	37	3.4	37	3.4	44	3.1	190
200							28	2.4	31	2.6	31	2.3	40	2.6	200
210													36	2.3	210
220															220
230															230
240															240
250															250
Telescoping sequence %															
Tel. 1	100												Tel. 1		
Tel. 2	100												Tel. 2		
Tel. 3	100												Tel. 3		
Tel. 4	100												Tel. 4		

Operation and maintenance of this machine must be in compliance with the information provided in the "Operation and Maintenance Manual" supplied with this machine.

STERLING CRANE

Load rating charts

Counterweight 63,490 lbs

Working Radius (ft)		Lifting capacities in 1,000 lbs according per SAE J765 on fly jib 31.17 ft / 53.15 ft / 79.07 ft / 98.75 f												Working Radius (ft)			
		On outriggers, 360° working area															
		Outrigger base 24.61 ft															
		Boom length 42.7 ft to 160.4 ft															
		Fly jib 31.17 ft offset			Fly jib 53.15 ft offset			Fly jib 79.07 ft offset			Fly jib 98.75 ft offset						
		0°	20°	35°	0°	20°	35°	0°	20°	35°	0°	20°	35°				
		∠	∠	∠	∠	∠	∠	∠	∠	∠	∠	∠	∠				
35	79	17.0														35	
40	78	17.0	81	17.0												40	
45	76	17.0	79	17.0												45	
50	75	17.0	78	16.7												50	
55	74	17.0	76	16.3	78	12.7	76	12.3	80	10.9						55	
60	73	17.0	75	15.9	77	12.3	75	12.3	79	10.9						60	
65	71	17.0	74	15.6	75	11.9	73	12.3	77	10.7						65	
70	70	17.0	73	15.2	74	11.8	72	12.3	76	10.3	79	7.1	74	7.7	80	70	
75	68	16.5	71	14.7	72	11.4	71	12.3	75	10.0	77	7.0	73	7.6	79	75	
80	67	15.8	70	14.2	71	11.1	70	12.3	74	9.6	76	6.8	72	7.4	78	80	
85	65	15.2	68	13.6	69	10.9	68	12.1	72	9.3	75	6.5	71	7.2	76	85	
90	64	14.6	66	13.1	68	10.8	67	11.8	71	8.9	74	6.3	70	7.0	75	90	
95	62	14.0	64	12.6	66	10.6	66	11.5	69	8.5	72	6.2	69	6.7	74	95	
100	61	13.4	63	12.2	65	10.4	65	11.2	68	8.2	71	6.1	68	6.3	73	100	
110	57	11.7	59	11.5	61	10.0	64	10.1	64	7.6	67	5.9	64	5.7	69	110	
120	53	9.5	55	10.2	57	9.6	58	9.3	61	7.2	64	5.7	62	5.1	67	120	
130	49	7.7	52	8.3	53	8.5	55	8.6	58	6.8	60	5.5	59	4.7	64	130	
140	45	5.9	47	6.5	48	6.6	51	7.4	55	6.3	57	5.3	56	4.3	61	140	
150	40	4.7	42	5.0	43	5.0	48	6.0	51	6.1	53	5.2	53	3.9	58	150	
160	34	3.3	36	3.6	36	3.6	44	4.8	47	5.3	49	5.0	50	3.6	55	160	
170	27	2.5	29	2.5	29	2.4	39	3.7	42	4.1	44	4.2	47	3.3	52	170	
180	18	1.8	19	1.8			34	2.7	37	3.1	38	3.1	44	3.1	49	180	
190							28	2.0	31	2.0	30	2.0	40	2.4	44	190	
200													36	1.8	40	200	
210															42	210	
220															2.5	220	
230																230	
240																240	
250																250	
Telescoping sequence %																	
Tel. 1	92																Tel. 1
Tel. 2	92																Tel. 2
Tel. 3	92																Tel. 3
Tel. 4	92																Tel. 4

Operation and maintenance of this machine must be in compliance with the information provided in the "Operation and Maintenance Manual" supplied with this machine.

Counterweight 63,490 lbs

Working Radius (ft)		Lifting capacities in 1,000 lbs according per SAE J765 on fly jib 31.17 ft / 53.15 ft / 79.07 ft / 98.75 f												Working Radius (ft)			
		On outriggers, 360° working area															
		Outrigger base 24.61 ft															
		Boom length 43.3 ft to 170.6 ft															
		Fly jib 31.17 ft offset			Fly jib 53.15 ft offset			Fly jib 79.07 ft offset			Fly jib 98.75 ft offset						
		0°	20°	35°	0°	20°	35°	0°	20°	35°	0°	20°	35°				
		∠	∠	∠	∠	∠	∠	∠	∠	∠	∠	∠	∠				
35	80	14.6														35	
40	79	14.6														40	
45	77	14.6														45	
50	76	14.6	79	14.6												50	
55	75	14.6	77	14.6	79	12.9	77	10.9								55	
60	74	14.6	76	14.6	78	12.5	76	10.9	79	9.7						60	
65	72	14.6	75	14.6	77	12.2	74	10.9	78	9.7						65	
70	71	14.6	74	14.4	76	12.0	73	10.9	77	9.4						70	
75	70	14.6	72	14.0	74	11.7	72	10.9	76	9.0	78	6.1	74	7.3	79	75	
80	69	14.3	71	13.5	73	11.3	71	10.9	75	8.6	77	5.9	73	7.2	78	80	
85	67	13.5	69	12.8	71	11.1	69	10.9	73	8.3	76	5.7	72	7.1	77	85	
90	66	12.7	68	12.1	70	10.8	68	10.8	72	8.1	75	5.7	71	7.0	76	90	
95	64	11.9	66	11.4	68	10.6	67	10.4	70	7.8	73	5.5	70	6.8	75	95	
100	63	11.1	65	10.7	67	10.3	66	10.0	69	7.4	72	5.3	69	6.6	74	100	
110	59	9.8	61	9.5	63	9.4	62	8.9	66	7.0	68	5.1	66	5.9	71	110	
120	55	8.7	58	8.4	59	8.4	60	8.0	63	6.4	65	4.9	64	5.4	69	120	
130	52	7.5	54	7.5	56	7.5	57	7.1	60	6.1	62	4.8	61	4.9	66	130	
140	48	5.9	50	6.5	52	6.6	54	6.4	57	5.8	59	4.6	59	4.5	63	140	
150	44	4.5	46	4.9	47	5.0	50	5.7	54	5.5	56	4.5	56	4.1	61	150	
160	39	3.3	41	3.6	42	3.7	47	4.6	50	5.0	52	4.4	53	3.8	58	160	
170	33	2.4	36	2.5	36	2.5	43	3.5	46	3.9	48	4.1	50	3.5	55	170	
180			29	1.8	29	1.8	39	2.6	42	3.0	43	3.1	47	3.1	52	180	
190							34	1.8	37	2.2	37	2.2	44	2.4	48	190	
200													40	1.8	45	200	
210															47	210	
220															2.4	220	
230																230	
240																240	
250																250	
Telescoping sequence %																	
Tel. 1	100																Tel. 1
Tel. 2	100																Tel. 2
Tel. 3	100																Tel. 3
Tel. 4	100																Tel. 4

STERLING CRANE

Load rating charts

Counterweight 45,855 lbs

Working Radius (ft)	Lifting capacities in 1,000 lbs according per SAE J765 on fly jib 31.17 ft / 53.15 ft / 79.07 ft / 98.75 ft												Working Radius (ft)		
	On outriggers, 360° working area														
	Outrigger base 24.61 ft														
	Boom length 42.7 ft to 160.4 ft														
	Fly jib 31.17 ft offset			Fly jib 53.15 ft offset			Fly jib 79.07 ft offset			Fly jib 98.75 ft offset					
	0°	20°	35°	0°	20°	35°	0°	20°	35°	0°	20°	35°			
35	79	17.0												35	
40	78	17.0	81	17.0										40	
45	76	17.0	79	17.0										45	
50	75	17.0	78	16.7										50	
55	74	17.0	76	16.3	78	12.7	76	12.3	80	10.9		77	7.7	55	
60	73	17.0	75	15.9	77	12.3	75	12.3	79	10.9		76	7.7	60	
65	71	17.0	74	15.6	75	11.9	73	12.3	77	10.7		75	7.7	65	
70	70	17.0	73	15.2	74	11.8	72	12.3	76	10.3	79	7.1	74	7.7	70
75	68	16.5	71	14.7	72	11.4	71	12.3	75	10.0	77	7.0	73	7.6	75
80	67	15.8	70	14.2	71	11.1	70	12.3	74	9.6	76	6.8	72	7.4	80
85	65	15.2	68	13.6	69	10.9	68	12.1	72	9.3	75	6.5	71	7.2	85
90	64	13.9	66	13.1	68	10.8	67	11.8	71	8.9	74	6.3	70	7.0	90
95	62	12.3	64	12.5	66	10.6	66	11.5	69	8.5	72	6.2	69	6.7	95
100	61	10.7	63	11.6	65	10.4	65	11.2	68	8.2	71	6.1	68	6.3	100
110	57	8.4	59	9.0	61	9.5	64	9.8	64	7.6	67	5.9	64	5.7	110
120	53	6.5	55	6.9	57	7.4	58	7.7	61	7.2	64	5.7	62	5.1	120
130	49	4.8	52	5.3	53	5.5	55	6.0	58	6.8	60	5.5	59	4.7	130
140	45	3.3	47	3.6	48	3.9	51	4.6	55	5.4	57	5.3	56	4.3	140
150	40	2.1	42	2.3	43	2.6	48	3.5	51	4.0	53	4.4	53	3.9	150
160							44	2.4	47	2.9	49	3.1	50	3.1	160
170									42	2.0	44	2.0	47	2.2	170
180													49	1.9	180
190															190
200															200
210															210
220															220
230															230
240															240
250															250
Telescoping sequence %															
Tel. 1	92												Tel. 1		
Tel. 2	92												Tel. 2		
Tel. 3	92												Tel. 3		
Tel. 4	92												Tel. 4		

Operation and maintenance of this machine must be in compliance with the information provided in the "Operation and Maintenance Manual" supplied with this machine.

Counterweight 48,855 lbs

Working Radius (ft)	Lifting capacities in 1,000 lbs according per SAE J765 on fly jib 31.17 ft / 53.15 ft / 79.07 ft / 98.75 ft												Working Radius (ft)		
	On outriggers, 360° working area														
	Outrigger base 24.61 ft														
	Boom length 43.3 ft to 170.6 ft														
	Fly jib 31.17 ft offset			Fly jib 53.15 ft offset			Fly jib 79.07 ft offset			Fly jib 98.75 ft offset					
	0°	20°	35°	0°	20°	35°	0°	20°	35°	0°	20°	35°			
35	80	14.6												35	
40	79	14.6												40	
45	77	14.6												45	
50	76	14.6	79	14.6			78	10.9						50	
55	75	14.6	77	14.6	79	12.9	77	10.9					78	7.3	55
60	74	14.6	76	14.6	78	12.5	76	10.9	79	9.7			77	7.3	60
65	72	14.6	75	14.6	77	12.2	74	10.9	78	9.7			76	7.3	65
70	71	14.6	74	14.4	76	12.0	73	10.9	77	9.4			75	7.3	70
75	70	14.6	72	14.0	74	11.7	72	10.9	76	9.0	78	6.1	74	7.3	75
80	69	14.3	71	13.5	73	11.3	71	10.9	75	8.6	77	5.9	73	7.2	80
85	67	13.5	69	12.8	71	11.1	69	10.9	73	8.3	76	5.7	72	7.1	85
90	66	12.7	68	12.1	70	10.8	68	10.8	72	8.1	75	5.7	71	7.0	90
95	64	11.8	66	11.4	68	10.6	67	10.4	70	7.8	73	5.5	70	6.8	95
100	63	10.7	65	10.7	67	10.3	66	10.0	69	7.4	72	5.3	69	6.6	100
110	59	8.4	61	9.0	63	9.3	62	8.9	66	7.0	68	5.1	66	5.9	110
120	55	6.2	58	6.9	59	7.4	60	7.7	63	6.4	65	4.9	64	5.4	120
130	52	4.6	54	5.1	56	5.5	57	5.8	60	6.1	62	4.8	61	4.9	130
140	48	3.2	50	3.6	52	3.9	54	4.5	57	5.3	59	4.6	59	4.5	140
150	44	2.1	46	2.3	47	2.6	50	3.2	54	4.0	56	4.4	56	3.9	150
160							47	2.3	50	2.9	52	3.1	53	2.9	160
170									48	2.0	50	2.0	55	2.7	170
180													52	2.0	180
190															190
200															200
210															210
220															220
230															230
240															240
250															250
Telescoping sequence %															
Tel. 1	100												Tel. 1		
Tel. 2	100												Tel. 2		
Tel. 3	100												Tel. 3		
Tel. 4	100												Tel. 4		

Operation and maintenance of this machine must be in compliance with the information provided in the "Operation and Maintenance Manual" supplied with this machine.

STERLING CRANE

Load rating charts

Counterweight 24,250 lbs

Working Radius (ft)	Lifting capacities in 1,000 lbs according per SAE J765 on fly jib 31.17 ft / 53.15 ft / 79.07 ft / 98.75 ft												Working Radius (ft)			
	On outriggers, 360° working area															
	Outrigger base 24.61 ft															
	Boom length 42.7 ft to 160.4 ft															
	Fly jib 31.17 ft offset			Fly jib 53.15 ft offset			Fly jib 79.07 ft offset			Fly jib 98.75 ft offset						
	0°	20°	35°	0°	20°	35°	0°	20°	35°	0°	20°	35°				
35	79	17.0												35		
40	78	17.0	81	17.0										40		
45	76	17.0	79	17.0										45		
50	75	17.0	78	16.7			77	12.3		78	7.7			50		
55	74	17.0	76	16.3	78	12.7	76	12.3	80	10.9		77	7.7	55		
60	73	17.0	75	15.9	77	12.3	75	12.3	79	10.9		76	7.7	60		
65	71	17.0	74	15.6	75	11.9	73	12.3	77	10.7		75	7.7	65		
70	70	15.5	73	15.2	74	11.8	72	12.3	76	10.3	79	7.1	74	7.7	70	
75	68	13.6	71	14.3	72	11.4	71	12.3	75	10.0	77	7.0	73	7.6	75	
80	67	11.7	70	12.9	71	11.1	70	12.1	74	9.6	76	6.8	72	7.4	80	
85	65	9.8	68	11.0	69	10.9	68	11.2	72	9.3	75	6.5	71	7.2	85	
90	64	8.5	66	9.5	68	10.0	67	9.8	71	8.9	74	6.3	70	7.0	90	
95	62	7.2	64	8.1	66	8.8	66	8.5	69	8.5	72	6.2	69	6.7	95	
100	61	5.9	63	6.9	65	7.4	65	7.4	68	8.1	71	6.1	68	6.3	100	
110	57	3.9	59	4.7	61	5.2	64	5.4	64	6.6	67	5.9	64	5.7	110	
120	53	2.4	55	3.1	57	3.4	58	3.8	61	4.8	64	5.5	62	4.6	120	
130					53	2.0	55	2.4	58	3.4	60	4.0	59	3.1	130	
140									55	2.2	57	2.6	56	2.0	140	
150													58	2.1	150	
160														58	2.0	160
170																170
180																180
190																190
200																200
210																210
220																220
230																230
240																240
250																250
Telescoping sequence %																
Tel. 1	92												Tel. 1			
Tel. 2	92												Tel. 2			
Tel. 3	92												Tel. 3			
Tel. 4	92												Tel. 4			

Operation and maintenance of this machine must be in compliance with the information provided in the "Operation and Maintenance Manual" supplied with this machine.

Counterweight 24,250 lbs

Working Radius (ft)	Lifting capacities in 1,000 lbs according per SAE J765 on fly jib 31.17 ft / 53.15 ft / 79.07 ft / 98.75 ft												Working Radius (ft)			
	On outriggers, 360° working area															
	Outrigger base 24.61 ft															
	Boom length 43.3 ft to 170.6 ft															
	Fly jib 31.17 ft offset			Fly jib 53.15 ft offset			Fly jib 79.07 ft offset			Fly jib 98.75 ft offset						
	0°	20°	35°	0°	20°	35°	0°	20°	35°	0°	20°	35°				
35	80	14.6												35		
40	79	14.6												40		
45	77	14.6												45		
50	76	14.6	79	14.6			78	10.9						50		
55	75	14.6	77	14.6	79	12.9	77	10.9			78	7.3		55		
60	74	14.6	76	14.6	78	12.5	76	10.9	79	9.7		77	7.3	60		
65	72	14.6	75	14.6	77	12.2	74	10.9	78	9.7		76	7.3	65		
70	71	14.6	74	14.4	76	12.0	73	10.9	77	9.4		75	7.3	70		
75	70	13.4	72	14.0	74	11.7	72	10.9	76	9.0	78	6.1	74	7.3	75	
80	69	11.5	71	12.9	73	11.3	71	10.9	75	8.6	77	5.9	73	7.2	80	
85	67	9.8	69	11.0	71	11.1	69	10.9	73	8.3	76	5.7	72	7.1	85	
90	66	8.3	68	9.5	70	10.1	68	9.7	72	8.1	75	5.7	71	7.0	90	
95	64	7.0	66	8.0	68	8.8	67	8.4	70	7.8	73	5.5	70	6.8	95	
100	63	5.9	65	6.7	67	7.4	66	7.2	69	7.4	72	5.3	69	6.6	100	
110	59	3.9	61	4.7	63	5.2	62	5.1	66	6.5	68	5.1	66	5.8	110	
120	55	2.4	58	2.9	59	3.4	60	3.6	63	4.8	65	4.9	64	4.3	120	
130					56	1.8	57	2.3	60	3.4	62	4.0	61	3.0	130	
140									57	1.9	59	2.6			140	
150													63	3.2	150	
160														61	2.1	160
170																170
180																180
190																190
200																200
210																210
220																220
230																230
240																240
250																250
Telescoping sequence %																
Tel. 1	100												Tel. 1			
Tel. 2	100												Tel. 2			
Tel. 3	100												Tel. 3			
Tel. 4	100												Tel. 4			

Operation and maintenance of this machine must be in compliance with the information provided in the "Operation and Maintenance Manual" supplied with this machine.

STERLING CRANE

Load rating charts

Counterweight 19,180 lbs

Working Radius (ft)	Lifting capacities in 1,000 lbs according per SAE J765 on fly jib 31.17 ft / 53.15 ft / 79.07 ft / 98.75 ft												Working Radius (ft)			
	On outriggers, 360° working area															
	Outrigger base 24.61 ft															
	Boom length 42.7 ft to 160.4 ft															
	Fly jib 31.17 ft offset			Fly jib 53.15 ft offset			Fly jib 79.07 ft offset			Fly jib 98.75 ft offset						
	0°	20°	35°	0°	20°	35°	0°	20°	35°	0°	20°	35°				
35	79	17.0												35		
40	78	17.0	81	17.0										40		
45	76	17.0	79	17.0										45		
50	75	17.0	78	16.7										50		
55	74	17.0	76	16.3	78	12.7	76	12.3	80	10.9				55		
60	73	16.9	75	15.9	77	12.3	75	12.3	79	10.9				60		
65	71	16.5	74	15.6	75	11.9	73	12.3	77	10.7				65		
70	70	14.2	73	14.9	74	11.8	72	12.3	76	10.3	79	7.1	74	7.7	80	6.4
75	68	12.1	71	13.4	72	11.4	71	12.3	75	10.0	77	7.0	73	7.6	79	6.0
80	67	10.3	70	11.4	71	11.0	70	11.7	74	9.6	76	6.8	72	7.4	78	5.8
85	65	8.6	68	9.6	69	10.5	68	10.0	72	9.3	75	6.5	71	7.2	76	5.5
90	64	7.1	66	8.2	68	9.1	67	8.6	71	8.9	74	6.3	70	7.0	75	5.3
95	62	5.8	64	6.9	66	7.7	66	7.3	69	8.3	72	6.2	69	6.7	74	5.1
100	61	4.8	63	5.7	65	6.4	65	6.2	68	7.6	71	6.1	68	6.3	73	4.9
110	57	2.9	59	3.7	61	4.1	64	4.4	64	5.6	67	5.9	64	5.1	69	4.6
120			55	2.2	57	2.6	58	2.9	61	3.8	64	4.7	62	3.6	67	4.2
130									58	2.6	60	3.1	59	2.3	64	3.7
140																
150																
160																
170																
180																
190																
200																
210																
220																
230																
240																
250																
Telescoping sequence %																
Tel. 1	92													Tel. 1		
Tel. 2	92													Tel. 2		
Tel. 3	92													Tel. 3		
Tel. 4	92													Tel. 4		

Operation and maintenance of this machine must be in compliance with the information provided in the "Operation and Maintenance Manual" supplied with this machine.

Counterweight 19,180 lbs

Working Radius (ft)	Lifting capacities in 1,000 lbs according per SAE J765 on fly jib 31.17 ft / 53.15 ft / 79.07 ft / 98.75 ft												Working Radius (ft)			
	On outriggers, 360° working area															
	Outrigger base 24.61 ft															
	Boom length 43.3 ft to 170.6 ft															
	Fly jib 31.17 ft offset			Fly jib 53.15 ft offset			Fly jib 79.07 ft offset			Fly jib 98.75 ft offset						
	0°	20°	35°	0°	20°	35°	0°	20°	35°	0°	20°	35°				
35	80	14.6												35		
40	79	14.6												40		
45	77	14.6												45		
50	76	14.6	79	14.6										50		
55	75	14.6	77	14.6	79	12.9	77	10.9						55		
60	74	14.6	76	14.6	78	12.5	76	10.9	79	9.7				60		
65	72	14.6	75	14.6	77	12.2	74	10.9	78	9.7				65		
70	71	13.6	74	14.4	76	12.0	73	10.9	77	9.4				70		
75	70	12.0	72	13.2	74	11.7	72	10.9	76	9.0	78	6.1	74	7.3	79	6.1
80	69	10.0	71	11.3	73	11.2	71	10.7	75	8.6	77	5.9	73	7.2	78	5.9
85	67	8.4	69	9.5	71	10.5	69	9.8	73	8.3	76	5.7	72	7.1	77	5.7
90	66	7.0	68	8.0	70	9.1	68	8.5	72	8.1	75	5.7	71	7.0	76	5.4
95	64	5.8	66	6.8	68	7.5	67	7.2	70	7.8	73	5.5	70	6.8	75	5.2
100	63	4.8	65	5.7	67	6.2	66	6.0	69	7.3	72	5.3	69	6.5	74	5.0
110	59	2.9	61	3.7	63	4.1	62	4.1	66	5.4	68	5.1	66	4.9	71	4.7
120			58	2.2	59	2.4	60	2.6	63	3.8	65	4.6	64	3.4	69	4.4
130									60	2.4	62	3.1	61	2.1	66	3.5
140																
150																
160																
170																
180																
190																
200																
210																
220																
230																
240																
250																
Telescoping sequence %																
Tel. 1	100													Tel. 1		
Tel. 2	100													Tel. 2		
Tel. 3	100													Tel. 3		
Tel. 4	100													Tel. 4		

Operation and maintenance of this machine must be in compliance with the information provided in the "Operation and Maintenance Manual" supplied with this machine.

STERLING CRANE

Load rating charts

Counterweight 0 lbs

Working Radius (ft)	Lifting capacities in 1,000 lbs according per SAE J765 on fly jib 31.17 ft / 53.15 ft On outriggers, 360° working area Outrigger base 24.61 ft																								Working Radius (ft)													
	Boom length 42.7 ft to 160.4 ft												Boom length 42.7 ft to 170.6 ft																									
	Fly jib 31.17 ft offset						Fly jib 53.15 ft offset						Fly jib 31.17 ft offset						Fly jib 53.15 ft offset																			
	0°		20°		35°		0°		20°		35°		0°		20°		35°		0°		20°		35°															
35	79	17.0																						80	14.6												35	
40	78	17.0	81	17.0																					79	14.6											40	
45	76	17.0	79	17.0																					77	14.6											45	
50	75	16.7	78	16.7																					76	14.6	79	14.6								78	10.9	50
55	74	14.9	76	15.8	78	12.7	76	12.3	80	10.9															75	13.6	77	14.5	79	12.9	77	10.9					55	
60	73	11.8	75	14.0	77	12.3	75	12.1	79	10.9															74	11.6	76	13.8	78	12.5	76	10.8	79	9.7			60	
65	71	9.2	74	11.3	75	11.9	73	10.6	77	10.7															72	9.1	75	11.1	77	12.2	74	10.3	78	9.7			65	
70	70	7.2	73	9.0	74	10.0	72	8.8	76	10.3	79	7.1	71	7.1	74	8.9	76	10.1	73	8.6	77	9.4														70		
75	68	5.5	71	7.1	72	8.0	71	7.1	75	9.4	77	7.0	70	5.4	72	7.0	74	8.0	72	6.9	76	8.7	78	6.1												75		
80	67	4.0	70	5.5	71	6.4	70	5.6	74	8.0	76	6.8	69	3.9	71	5.5	73	6.3	71	5.4	75	7.7	77	5.9												80		
85	65	2.7	68	4.1	69	4.9	68	4.3	72	6.5	75	6.5	67	2.7	69	3.9	71	4.8	69	4.0	73	6.3	76	5.7												85		
90			66	2.9	68	3.6	67	3.2	71	5.2	74	6.1																									90	
95			64	1.9	66	2.5	66	2.2	69	4.1	72	5.3																									95	
100									68	3.1	71	4.2																									100	
110											67	2.3																									110	
120																																					120	
130																																					130	
140																																					140	
150																																					150	
160																																					160	
170																																					170	
180																																					180	
190																																					190	
200																																					200	
210																																					210	
220																																					220	
230																																					230	
240																																					240	
250																																					250	
Telescoping sequence %																																						
Tel. 1													92												100				Tel. 1									
Tel. 2													92												100				Tel. 2									
Tel. 3													92												100				Tel. 3									
Tel. 4													92												100				Tel. 4									

Operation and maintenance of this machine must be in compliance with the information provided in the "Operation and Maintenance Manual" supplied with this machine.

STERLING CRANE

Load rating charts

Counterweight 77,160 lbs

Working Radius (ft)	Lifting capacities in 1,000 lbs according per SAE J765 on fly jib 31.17 ft / 53.15 ft / 79.07 ft / 98.75 ft												Working Radius (ft)						
	On outriggers, 360° working area																		
	Outrigger base 16.40 ft																		
	Boom length 42.7 ft to 160.4 ft																		
	Fly jib 31.17 ft offset			Fly jib 53.15 ft offset			Fly jib 79.07 ft offset			Fly jib 98.75 ft offset									
	0°	20°	35°	0°	20°	35°	0°	20°	35°	0°	20°	35°							
35	79	17.0												35					
40	78	17.0	81	17.0										40					
45	76	17.0	79	17.0										45					
50	75	17.0	78	16.7										50					
55	74	17.0	76	16.3	78	12.7	76	12.3	80	10.9	77	7.7		55					
60	73	17.0	75	15.9	77	12.3	75	12.3	79	10.9	76	7.7	82	7.0	78	5.6		60	
65	71	17.0	74	15.6	75	11.9	73	12.3	77	10.7	75	7.7	81	6.8	76	5.6		65	
70	70	17.0	73	15.2	74	11.8	72	12.3	76	10.3	79	7.1	74	7.7	80	6.4		70	
75	68	16.3	71	14.7	72	11.4	71	12.3	75	10.0	77	7.0	73	7.6	79	6.0		75	
80	67	14.9	70	14.2	71	11.1	70	12.3	74	9.6	76	6.8	72	7.4	78	5.8		80	
85	65	13.1	68	13.6	69	10.9	68	12.1	72	9.3	75	6.5	71	7.2	76	5.5		85	
90	64	11.6	66	12.5	68	10.8	67	11.8	71	8.9	74	6.3	70	7.0	75	5.3	79	3.9	90
95	62	10.3	64	11.1	66	10.6	66	11.2	69	8.5	72	6.2	69	6.7	74	5.1	78	3.8	95
100	61	9.1	63	9.8	65	10.1	65	10.2	68	8.2	71	6.1	68	6.3	73	4.9	77	3.7	100
110	57	6.9	59	7.6	61	8.0	64	8.2	64	7.6	67	5.9	64	5.7	69	4.6	73	3.6	110
120	53	5.3	55	5.9	57	6.1	58	6.5	61	7.1	64	5.7	62	5.1	67	4.2	71	3.4	120
130	49	3.9	52	4.4	53	4.6	55	5.0	58	5.9	60	5.5	59	4.7	64	3.9	68	3.3	130
140	45	2.6	47	3.0	48	3.2	51	3.7	55	4.6	57	4.9	56	4.2	61	3.7	65	3.2	140
150			42	1.9	43	2.1	48	2.7	51	3.4	53	3.7	53	3.4	58	3.4	62	3.1	150
160							47	2.4	49	2.6	50	2.5	55	3.2	58	2.9	55	2.5	160
170													52	2.5	55	2.8	52	2.0	170
180															51	2.0			180
190																			190
200																			200
210																			210
220																			220
230																			230
240																			240
250																			250
Telescoping sequence %																			
Tel. 1														Tel. 1					
Tel. 2														Tel. 2					
Tel. 3														Tel. 3					
Tel. 4														Tel. 4					

Operation and maintenance of this machine must be in compliance with the information provided in the "Operation and Maintenance Manual" supplied with this machine.

Counterweight 77,160 lbs

Working Radius (ft)	Lifting capacities in 1,000 lbs according per SAE J765 on fly jib 31.17 ft / 53.15 ft / 79.07 ft / 98.75 ft												Working Radius (ft)						
	On outriggers, 360° working area																		
	Outrigger base 16.40 ft																		
	Boom length 43.3 ft to 170.6 ft																		
	Fly jib 31.17 ft offset			Fly jib 53.15 ft offset			Fly jib 79.07 ft offset			Fly jib 98.75 ft offset									
	0°	20°	35°	0°	20°	35°	0°	20°	35°	0°	20°	35°							
35	80	14.6												35					
40	79	14.6												40					
45	77	14.6												45					
50	76	14.6	79	14.6		78	10.9							50					
55	75	14.6	77	14.6	79	12.9	77	10.9			78	7.3		55					
60	74	14.6	76	14.6	78	12.5	76	10.9	79	9.7	77	7.3		60					
65	72	14.6	75	14.6	77	12.2	74	10.9	78	9.7	76	7.3		65					
70	71	14.6	74	14.4	76	12.0	73	10.9	77	9.4	75	7.3	80	6.5	70				
75	70	14.6	72	14.0	74	11.7	72	10.9	76	9.0	78	6.1	74	7.3	79	6.1	75		
80	69	14.2	71	13.5	73	11.3	71	10.9	75	8.6	77	5.9	73	7.2	78	5.9	80		
85	67	13.0	69	12.8	71	11.1	69	10.9	73	8.3	76	5.7	72	7.1	77	5.7	85		
90	66	11.6	68	12.1	70	10.8	68	10.8	72	8.1	75	5.7	71	7.0	76	5.4	90		
95	64	10.2	66	11.0	68	10.6	67	10.4	70	7.8	73	5.5	70	6.8	75	5.2	79	3.9	95
100	63	8.9	65	9.8	67	11.7	72	10.9	69	7.4	72	5.3	69	6.6	74	5.0	78	3.8	100
110	59	6.9	61	7.6	63	8.0	62	8.0	66	7.0	68	5.1	66	5.9	71	4.7	75	3.6	110
120	55	5.2	58	5.9	59	6.1	60	6.4	63	6.4	65	4.9	64	5.4	69	4.4	72	3.5	120
130	52	3.7	54	4.4	56	4.6	57	4.8	60	5.7	62	4.8	61	4.9	66	4.0	69	3.3	130
140	48	2.6	50	3.0	52	3.2	54	3.7	57	4.4	59	4.6	59	4.2	63	3.8	67	3.3	140
150			46	1.9	47	2.1	50	2.7	54	3.2	56	3.7	56	3.2	61	3.5	64	3.1	150
160							50	2.3	52	2.6	53	2.3	58	3.2	61	3.0	57	2.5	160
170													55	2.3	58	2.8	54	1.8	170
180															54	2.0			180
190																			190
200																			200
210																			210
220																			220
230																			230
240																			240
250																			250
Telescoping sequence %																			
Tel. 1														Tel. 1					
Tel. 2														Tel. 2					
Tel. 3														Tel. 3					
Tel. 4														Tel. 4					

Operation and maintenance of this machine must be in compliance with the information provided in the "Operation and Maintenance Manual" supplied with this machine.

STERLING CRANE

Load rating charts

Counterweight 63,490 lbs

Working Radius (ft)	Lifting capacities in 1,000 lbs according per SAE J765 on fly jib 31.17 ft / 53.15 ft / 79.07 ft / 98.75 ft												Working Radius (ft)				
	On outriggers, 360° working area																
	Outrigger base 16.40 ft																
	Boom length 42.7 ft to 160.4 ft																
	Fly jib 31.17 ft offset			Fly jib 53.15 ft offset			Fly jib 79.07 ft offset			Fly jib 98.75 ft offset							
	0°	20°	35°	0°	20°	35°	0°	20°	35°	0°	20°	35°					
35	79	17.0												35			
40	78	17.0	81	17.0										40			
45	76	17.0	79	17.0										45			
50	75	17.0	78	16.7			77	12.3			78	7.7		50			
55	74	17.0	76	16.3	78	12.7	76	12.3	80	10.9		77	7.7	55			
60	73	17.0	75	15.9	77	12.3	75	12.3	79	10.9		76	7.7	60			
65	71	17.0	74	15.6	75	11.9	73	12.3	77	10.7		75	7.7	65			
70	70	15.5	73	15.2	74	11.8	72	12.3	76	10.3	79	7.1	74	7.7	70		
75	68	13.8	71	14.5	72	11.4	71	12.3	75	10.0	77	7.0	73	7.6	75		
80	67	12.1	70	13.3	71	11.1	70	12.2	74	9.6	76	6.8	72	7.4	80		
85	65	10.5	68	11.6	69	10.9	68	11.7	72	9.3	75	6.5	71	7.2	85		
90	64	9.1	66	10.1	68	10.4	67	10.4	71	8.9	74	6.3	70	7.0	90		
95	62	7.9	64	8.9	66	9.4	66	9.2	69	8.5	72	6.2	69	6.7	95		
100	61	6.7	63	7.2	65	8.1	65	8.1	68	8.2	71	6.1	68	6.3	100		
110	57	4.9	59	5.7	61	6.0	64	6.2	64	7.3	67	5.9	64	5.7	110		
120	53	3.4	55	4.0	57	4.3	58	4.6	61	5.7	64	5.7	62	5.0	120		
130	49	2.1	52	2.7	53	2.9	55	3.3	58	4.2	60	4.8	59	4.0	130		
140						51	2.3	55	3.0	57	3.5	56	2.9	61	3.7	140	
150								51	2.0	53	2.3	53	2.0	58	3.1	150	
160													55	2.1	58	2.6	160
170																	170
180																	180
190																	190
200																	200
210																	210
220																	220
230																	230
240																	240
250																	250
Telescoping sequence %																	
Tel. 1	92												Tel. 1				
Tel. 2	92												Tel. 2				
Tel. 3	92												Tel. 3				
Tel. 4	92												Tel. 4				

Operation and maintenance of this machine must be in compliance with the information provided in the "Operation and Maintenance Manual" supplied with this machine.

Counterweight 63,490 lbs

Working Radius (ft)	Lifting capacities in 1,000 lbs according per SAE J765 on fly jib 31.17 ft / 53.15 ft / 79.07 ft / 98.75 ft												Working Radius (ft)				
	On outriggers, 360° working area																
	Outrigger base 16.40 ft																
	Boom length 43.3 ft to 170.6 ft																
	Fly jib 31.17 ft offset			Fly jib 53.15 ft offset			Fly jib 79.07 ft offset			Fly jib 98.75 ft offset							
	0°	20°	35°	0°	20°	35°	0°	20°	35°	0°	20°	35°					
35	80	14.6												35			
40	79	14.6												40			
45	77	14.6												45			
50	76	14.6	79	14.6		78	10.9							50			
55	75	14.6	77	14.6	79	12.9	77	10.9				78	7.3	55			
60	74	14.6	76	14.6	78	12.5	76	10.9	79	9.7		77	7.3	60			
65	72	14.6	75	14.6	77	12.2	74	10.9	78	9.7		76	7.3	65			
70	71	14.6	74	14.4	76	12.0	73	10.9	77	9.4		75	7.3	70			
75	70	13.6	72	14.0	74	11.7	72	10.9	76	9.0	78	6.1	74	7.3	75		
80	69	12.0	71	13.5	73	11.3	71	10.9	75	8.6	77	5.9	73	7.2	80		
85	67	10.5	69	11.6	71	11.1	69	10.9	73	8.3	76	5.7	72	7.1	85		
90	66	9.1	68	10.1	70	10.4	68	10.0	72	8.1	75	5.7	71	7.0	90		
95	64	7.9	66	8.8	68	9.4	67	9.0	70	7.8	73	5.5	70	6.8	95		
100	63	6.7	65	7.6	67	8.1	66	7.9	69	7.4	72	5.3	69	6.6	100		
110	59	4.9	61	5.7	63	6.0	62	6.0	66	7.0	68	5.1	66	5.9	110		
120	55	3.4	58	4.0	59	4.3	60	4.5	63	5.6	65	4.9	64	5.1	120		
130	52	2.1	54	2.6	56	2.9	57	3.2	60	4.2	62	4.6	61	3.8	130		
140						54	2.1	57	3.0	59	3.5	59	2.8	63	3.7	140	
150								54	2.0	56	2.3	56	1.8	61	3.0	150	
160														58	2.0	160	
170																	170
180																	180
190																	190
200																	200
210																	210
220																	220
230																	230
240																	240
250																	250
Telescoping sequence %																	
Tel. 1	100												Tel. 1				
Tel. 2	100												Tel. 2				
Tel. 3	100												Tel. 3				
Tel. 4	100												Tel. 4				

Operation and maintenance of this machine must be in compliance with the information provided in the "Operation and Maintenance Manual" supplied with this machine.

STERLING CRANE

Load rating charts

Counterweight 45,855 lbs

Working Radius (ft)	Lifting capacities in 1,000 lbs according per SAE J765 on fly jib 31.17 ft / 53.15 ft / 79.07 ft / 98.75 ft												Working Radius (ft)				
	On outriggers, 360° working area																
	Outrigger base 16.40 ft																
	Boom length 42.7 ft to 160.4 ft																
	Fly jib 31.17 ft offset			Fly jib 53.15 ft offset			Fly jib 79.07 ft offset			Fly jib 98.75 ft offset							
	0°	20°	35°	0°	20°	35°	0°	20°	35°	0°	20°	35°					
35	79	17.0												35			
40	78	17.0	81	17.0										40			
45	76	17.0	79	17.0										45			
50	75	17.0	78	16.7										50			
55	74	16.1	76	16.3	78	12.7	76	12.3	80	10.9		77	7.7	55			
60	73	14.4	75	15.9	77	12.3	75	12.3	79	10.9		76	7.7	60			
65	71	12.6	74	14.1	75	11.9	73	12.3	77	10.7		75	7.7	65			
70	70	10.9	73	12.3	74	11.8	72	12.2	76	10.3	79	7.1	74	7.7	70		
75	68	9.4	71	10.7	72	11.3	71	11.0	75	10.0	77	7.0	73	7.6	75		
80	67	8.1	70	9.4	71	10.3	70	9.2	74	9.6	76	6.8	72	7.4	80		
85	65	6.9	68	8.0	69	8.9	68	8.0	72	9.3	75	6.5	71	7.2	85		
90	64	5.9	66	6.8	68	7.6	67	7.0	71	8.6	74	6.3	70	7.0	90		
95	62	4.9	64	5.8	66	6.4	66	6.1	69	7.6	72	6.2	69	6.5	95		
100	61	3.9	63	4.8	65	5.4	65	5.2	68	6.5	71	6.1	68	5.8	100		
110	57	2.4	59	3.1	61	3.6	64	3.6	64	4.7	67	5.4	64	4.2	110		
120					57	1.9	58	2.4	61	3.3	64	3.9	62	2.9	120		
130									58	2.1	60	2.6	59	1.9	130		
140													61	2.0	140		
150														65	2.9	150	
160															62	1.9	160
170																	170
180																	180
190																	190
200																	200
210																	210
220																	220
230																	230
240																	240
250																	250
Telescoping sequence %																	
Tel. 1	92												Tel. 1				
Tel. 2	92												Tel. 2				
Tel. 3	92												Tel. 3				
Tel. 4	92												Tel. 4				

Operation and maintenance of this machine must be in compliance with the information provided in the "Operation and Maintenance Manual" supplied with this machine.

Counterweight 45,855 lbs

Working Radius (ft)	Lifting capacities in 1,000 lbs according per SAE J765 on fly jib 31.17 ft / 53.15 ft / 79.07 ft / 98.75 ft												Working Radius (ft)				
	On outriggers, 360° working area																
	Outrigger base 16.40 ft																
	Boom length 43.3 ft to 170.6 ft																
	Fly jib 31.17 ft offset			Fly jib 53.15 ft offset			Fly jib 79.07 ft offset			Fly jib 98.75 ft offset							
	0°	20°	35°	0°	20°	35°	0°	20°	35°	0°	20°	35°					
35	80	14.6												35			
40	79	14.6												40			
45	77	14.6												45			
50	76	14.6	79	14.6			78	10.9						50			
55	75	14.6	77	14.6	79	12.9	77	10.9				78	7.3	55			
60	74	14.2	76	14.6	78	12.5	76	10.9	79	9.7		77	7.3	60			
65	72	12.2	75	14.6	77	12.2	74	10.9	78	9.7		76	7.3	65			
70	71	10.6	74	12.3	76	12.0	73	10.9	77	9.4		75	7.3	70			
75	70	9.2	72	10.4	74	11.4	72	10.1	76	9.0	78	6.1	74	7.3	75		
80	69	7.9	71	9.0	73	10.3	71	8.7	75	8.6	77	5.9	73	7.2	80		
85	67	6.7	69	7.8	71	8.7	69	7.6	73	8.3	76	5.7	72	7.1	85		
90	66	5.7	68	6.8	70	7.5	68	6.7	72	8.1	75	5.7	71	7.0	90		
95	64	4.8	66	5.8	68	6.3	67	5.9	70	6.3	73	5.5	70	6.3	95		
100	63	3.9	65	4.8	67	5.2	66	5.0	69	6.3	72	5.3	69	5.3	100		
110	59	2.4	61	3.1	63	3.6	62	3.5	66	4.7	68	5.1	66	4.0	110		
120					59	1.9	60	2.2	63	3.3	65	3.9	64	2.7	120		
130									60	1.9	62	2.6				130	
140													63	2.0		140	
150														67	2.9	150	
160															64	1.9	160
170																	170
180																	180
190																	190
200																	200
210																	210
220																	220
230																	230
240																	240
250																	250
Telescoping sequence %																	
Tel. 1	100												Tel. 1				
Tel. 2	100												Tel. 2				
Tel. 3	100												Tel. 3				
Tel. 4	100												Tel. 4				

Operation and maintenance of this machine must be in compliance with the information provided in the "Operation and Maintenance Manual" supplied with this machine.

STERLING CRANE

WARNING AND OPERATING INSTRUCTIONS FOR LIFTING CAPACITIES

GENERAL

- Total rated load shown on the TADANO load rating chart apply only to the machine as originally manufactured and normally equipped by TADANO. Modifications to the machine or use of optional equipment other than that specified can result in a reduction of capacity.
- Hydraulic cranes can be hazardous if improperly operated or maintained. Operation and maintenance of this machine must be in compliance with the information in the **Operation and Maintenance Manual** supplied with the crane. If this manual is missing, order replacement through the distributor.
- The operator and other personnel associated with this machine shall fully acquaint themselves with the latest applicable American National Standards Institute (ANSI) safety standards for cranes.

SET UP

- Total rated loads shown on the TADANO load rating chart are the maximum allowable crane capacities. They are based on the machine standing level on firm supporting surface under ideal job conditions. Depending on the nature of the supporting surface, it may be necessary to have structural supports under the outrigger floats to spread the load to a larger bearing surface.
- For on outrigger operation, outriggers shall be extended to the dimension according to the TADANO LOAD RATING CHART and secured by pins with tires free of supporting surface, before operating crane.
- Working on tires are travelling with load is not allowed.
- The weight of the auxiliary winch with 3,100 lbs is taken into account as a part of counterweight. Therefore the auxiliary winch must be attached always at the superstructure for crane operation.

OPERATION

- Total rated loads with outriggers fully extended do not exceed 85% of the tipping loads. Total rated loads with outriggers half extended are determined from the formula:
total rated load = (tipping load - 0.1 tip reaction) / 1.25
- The crane's structural steelwork is in accordance with DIN 15018, part 3. Design and construction of the crane comply with DIN 15018, part 2 and with F.E.M. regulations.
- Total rated loads above the bold lines in the TADANO load rating chart are based on crane strength and those below the bold lines on crane stability.
- Total rated loads include the weight of main hook block, auxiliary hook ball, sling and other auxiliary lifting devices and all their weights shall be subtracted from the listed capacities to obtain the net load to be lifted.

Hookball/ Hookblock(ton)		11.0		27.5	
No. of parts of line		1		2	
Max. lifting capacity (ton)		8.8		18.7	
Weight (lbs.)		440		660	
69.5		88		138	
4	5	6	7	8	9
37.0	46.0	54.9	63.7	72.4	81.0
1,320		1,765		2,650	

- Total rated loads are based on freely suspended loads and make no allowance for such factors as the effect of wind, sudden stopping of loads, supporting surface conditions, operating speeds, side loads, etc. Side pull on boom or jib is **extremely dangerous**.
- Total rated loads do not account for wind on lifted load or boom. Total rated loads and boom length shall be appropriately reduced, when wind velocity is above 18 mph (26 ft/sec.) for main boom operation and above 11 mph (16 ft/sec.) for jib operation.
- Total rated loads at load radius shall not be exceeded. Do not tip the crane to determine allowable loads.
- Do not operate at boom lengths beyond radii or boom angles where no capacities are shown. Crane may overturn without any load on the hook.
- Slewing of the superstructure is admissible only when the crane is supported on half or fully extended outriggers.
- The lifting capacity ratings specified in the TADANO load rating chart apply to the telescopic boom without fly jib fixed in transport position or working position. If the fly jib is secured to the telescopic boom in transport position or working position, the lifting capacities of the telescopic boom are reduced by the values specified below. The weight of the fly jib (3,650 lbs) is detected in terms of a load, and the load moment limiter will shut off earlier.

Jib status	Load rating reduction (tons)									
	Boom length (ft)									
31.2ft/53.1ft fly jib, mounted in transport position	0.66	0.29	0.29	0.19	0.19	0.14	0.14	0.12	0.11	0.10
31.2ft fly jib, mounted to the boom head	2.59	2.12	1.94	1.84	1.80	1.73	1.70	1.68	1.61	1.54
53.1ft fly jib, mounted to the boom head	3.18	2.59	2.24	2.07	2.02	1.89	1.85	1.78	1.71	1.65
79.1ft fly jib, mounted to the boom head	5.18	3.77	3.23	2.94	2.87	2.63	2.63	2.44	2.32	2.15
98.8ft fly jib, mounted to the boom head	7.06	4.99	4.30	3.78	3.67	3.33	3.33	3.11	2.88	2.59

- When making lifts at a load radius not shown, use the next longer radius to determine allowable capacity.
- Load per part line should not exceed 18,650 lbs. for the main winch and for the auxiliary winch.
- Loaded boom angles are approximate. The boom angle before loading should be greater to account for deflection.
- The 42.7ft boom length capacities are based on the telescoping boom being fully retracted. If not fully retracted (less than 57.1ft boom length), use the total rated loads for the 57.1ft boom length according to the telescoping sequence.
- Extension or retraction of the telescopic boom with loads may be attempted within the limits of the TADANO LOAD RATING CHART. The ability to telescope loads is limited by hydraulic pressure, boom angle, boom length, crane maintenance, etc.
- When erecting or stowing the fly jib, be sure to retain it by hand or by other means to prevent its free movement.
- Use the Anti-Two Block (OVERWIND CUTOFF) disable switch when erecting or stowing the extendible fly jib and stowing the hook block. While the switch is pushed, the hoist will not stop, even when an overwind condition occurs.
- The working radius specified in the TADANO LOAD RATING CHARTS for the fly jib apply only if the telescopic boom is extended according to the TADANO LOAD RATING CHARTS. If one or more elements of the telescopic boom are retracted partially or completely, the specified boom angles will be decisive in determining total rated lifting capacities.
- When lifting a load by using the fly jib (auxiliary hoist) and telescopic boom (main hoist) simultaneously, do the following:
 - Select the correct program for the load moment device in accordance with jib length, jib offset angle, counterweight and outrigger base.
 - Before starting the operation, make sure that the weight of the load is within the total rated load for the fly jib.
- Safe Load Indicator (S.L.I.)
Before working with the telescopic boom or fly jib, make sure that the S.L.I. code is set according to the desired telescoping sequence while the telescopic boom is completely retracted. A change of the telescoping sequence is not permissible when the boom has been partially or fully extended. In order to change the S.L.I. code number, the boom must be fully retracted.
- Working with Single Top
Operation with the single top is allowed with the main winch and the auxiliary winch. The maximum allowed capacity is limited by the selected S.L.I. code for main boom operation according to existing counterweight and outrigger base at one side and by the single line pull which is limited by hydraulic pressure at the other side.

For operations with the single top mounted, use the TADANO LOAD RATING CHART for the telescopic boom in accordance with existing counterweight and outrigger base to find the total rated lifting capacity and also select the correct S.L.I. code for the telescopic boom in accordance with the existing counterweight and outrigger base. Find the total rated lifting capacity based on boom length and working radius. From that value, subtract 1,100 lbs and the weights of all lifting equipment used including hook block, sling and other auxiliary lifting devices. The result (<total rated lifting capacity> - <1,100 lbs> - <lifting equipment>) is the total rated lifting capacity for a single top lift.

DEFINITIONS

- Working Radius: Horizontal distance from a projection of the axis of rotation to supporting surface before loading to the center of the vertical hoist line or tackle with load applied. The deflection of the boom due to its deadweight and the rated load are taken into account.
- Loaded Boom Angle: The angle between the boom base section and the horizontal, after lifting the total rated load at the working radius.
- Working Area: Area measured in a circular arc about the centerline of rotation.
- Freely Suspended Load: Load hanging free with no direct external force applied except by the hoist line.
- Side Load: Horizontal side force applied to the lifted load either on the ground or in the air.

Safe Load Indicator

The Safe Load Indicator is intended as an aid to the operator. Under no condition should it be relied upon to replace of Load Rating Charts and Operating Instructions. Sole reliance upon the Safe Load Indicator Aids in place of good operating practice can cause an accident. The operator must exercise caution to assure safety.

STERLING CRANE

1. CRANE CARRIER

1.1 FRAME

FAUN purpose built, 5 axle, box-type, torsion resistant, welded construction made of high tensile steel with integrated outrigger housings. Equipped with front and rear fenders, front and rear towing and tie-down lugs and 2 access steps. Centralized lubrication system.

1.2 OUTRIGGERS

Four point, fully hydraulic, double telescopic outriggers with horizontal and vertical motions are independently controlled by electro-magnetic valves. Push button controls with level gauges on both sides of carrier and in super-structure cab. Vertical cylinders with integral holding valves. Large sized floats can be stored on vertical cylinders or on carrier for road travel. Outrigger base: length 24'7-1/4" (7.5m), width 25' 4-3/4"(7.74m) Mid. extension 16' 4-7/8" (5.0m). Outrigger floats: 1'9-5/16"(542mm) x 1'9-5/16"(542mm)

1.3 CARRIER ENGINE

Mercedes Benz 8 cylinder water-cooled diesel engine, model OM 502 LA (EUROMOT2,EPA), with hydrostatically driven fan and thermostatically controlled cooler. Displacement 971.98 in³, Rating 517 hp at 1,800 rpm: Torque 1,770 ft-lbs at 1,200 rpm.

1.4 TRANSMISSION

ZF AS-Tronic, type 16AS2602, with integrated interarder. Electro-pneumatically controlled dry clutch and fully automatic control system, 16 forward speeds and 2 reverse gears. Gear ratios: Forward: 14.12 / 11.68 / 9.54 / 7.89 / 6.52 / 5.39 / 4.57 / 3.78 / 3.09 / 2.56 / 2.09 / 1.73 / 1.43 / 1.18 / 1.00 / 0.83 Reverse: 13.07 / 10.81

1.5 TRANSFER CASE

Two-step transfer box, type VG3750, with on/off road drive. Gear ratios: On-road: 0.8 Off-road: 1.836

1.6 DRIVE

10x6 : 2nd, 4th and 5th axle are driven
10x8 (OPTIONAL) : 1st, 2nd, 4th and 5th axle are driven

1.7 AXLES

1st axle : steered, non driven (10x6)
steered, driven (10x8)
2nd axle : steered, driven with transverse differential lock,
reduction : 8.47
3rd axle : non steered, non driven, lift axle
4th axle : steered, driven with longitudinal differential lock and
transverse differential lock,
reduction : 8.47
5th axle : steered, driven with transverse differential lock,
reduction : 8.47

All steering knuckle bearings designed for minimum maintenance (yearly inspection).

1.8 SUSPENSION

Hydro-pneumatic, lockable with level adjustment. All axles have longitudinal and transverse trailing arms. With leveling adjustment and locked cylinders, the chassis can be tilted laterally and longitudinally by push buttons in the carrier cab, or from the control panel of the outrigger which adjust the stroke of each individual suspension cylinder.

Cylinder stroke: - 4-5/8" (- 118mm)
+6-1/4" (+ 158mm)

1.9 BRAKE SYSTEM

Service brake : Dual circuit compressed air system with air-dryer. ABS(OPTIONAL)
Parking brake : Spring loaded type, acting on 2nd,4th and 5th axles.
Auxiliary brake : Interder,engine exhaust brake and constant throttle engine brake system.

1.10 WHEELS AND TIRES

(10)11.00-25 steel disc wheels with (10)16.00R25 on / off-road profile tires and mud flaps.
Carrier width: 9'1/4" (2.75m) with 16.00R25 tires

1.11 STEERING SYSTEM

ZF semi block dual circuit hydraulic steering, Mechanical steering of two front axles with hydraulic booster and a emergency steering pump is flange-mounted to the transfer box.
Rear axles can also be steered electronically depends on the speed according to the steering angle of the front axles. Rear axles are locked in "centered" position automatically.

1.12 POWER TRAIN

Drive-shafts with cross-geared flanges virtually maintenance-free.

1.13 FUEL TANK CAPACITY

132 gal (500 l) filler cap lockable.

1.14 CARRIER CAB

Two man full width cab of composite structure (steel sheet metal and fiber glass), windshield of laminated safety glass with windshield wiper and washer, sliding side windows of tempered glass. Driver and co-driver seats adjustable and air-suspended with integrated 3 point safety belts and headrests. 2 rear-view mirrors (electrically adjustable), 1 wide angle mirror and additional curb mirror, all mirrors heated, Radio with CD player and connections for wireless. Engine dependent warm-water heater with defroster nozzles for windshield and cab floor. Cruise control function. Single-key system. Instrumentation includes speedometer, odometer, tachograph, rpm counter with hour meter, fuel level gauge, warning light from the engine temperature, gearbox display, colour display indicating further warning signals and operating functions and the compressed air system. Air conditioner(OPTIONAL)

1.15 ELECTRICAL SYSTEM

24 volt DC system with 100 ampere 3-phase generator, and two 12 volt, 170 Ah batteries.
Front lighting includes 2 main head lights, 2 high beam lights, 2 directional indicators and 2 parking lights. Rear lighting includes 2 rear combi panels each with directional indicator, parking light, brake light, fog light, reversing light and license plate light.
Side lighting includes 2 front directional indicators and reflectors on carrier.
Other equipment includes hazard warning light system, cab light, instrument panel light, signal horn and amber rotating beacon on cab roof.
Charging plugbox. Back up alarm. 2 front fog lights. 4 lights to illuminate the area of the extended outriggers. Lighting according to EEC regulations.

STERLING CRANE

1.16 TOOLS AND ACCESSORIES

Special tool set, hazard warning triangle, hazard flashing lamp, fire extinguisher and first aid kit.

1.17 PAINTING

Standard TADANO colors

1.18 DIMENSIONS

Overall width : 9'1/4" (2.75m) with 16.00R25 tires
9'10-1/8" (3.0m) with 20.5R25 tires (OPTIONAL)

Overall height : 12'11-1/2" (3.95m)
In travel condition, the overall height can be adjusted - 4-5/8" / + 6-1/4"

Overall length : 49' 7/16" (14.946m)
51' 4-1/8" (15.649m) with Aux. winch

Carrier length : 39'6-7/16" (12.05m)

Wheel base : 8' 4-13/16" + 5' 4-15/16" + 5'11-1/4" + 5' 6-15/16"
(2.56m + 1.65m + 1.81m + 1.7m)

1.19 CARRIER OPTIONAL EQUIPMENT

1. Air conditioning
2. 20.5R25 on/off road profile tires
3. Spare wheel & tire
4. 10x8(1st, 2nd, 4th, 5th axles driven)
5. ABS
6. Eddy current brake (retarder)
7. Rear view camera(image displayed in carrier cab)
8. Spark arrester
9. Toolbox rear
10. Towing attachment(D-Value 190 kN)
11. Pneumatic and electrical quick disconnect connectors mounted on rear bumper for boom dolly

2. TRAVEL PERFORMANCE (according to DIN 70020)

Max. travel speed : 52.8 mph

Max. gradeability : 61 %

Gear	16.00R25 / 20.5R25 tires, GVW 132,275 lb			
	Travelling speed (mph)		Gradabilities (%)	
	Off-road gear	On -road gear	Off-road gear	On -road gear
1st	1.9	3.7	61	47
2nd	1.9	4.3	47	39
3rd	2.5	5.0	37	31
4th	2.5	6.2	30	25
5th	3.1	7.5	24	20
6th	4.3	9.3	19	16
7th	5.0	11.2	16	14
8th	5.6	13.0	13	11
9th	6.8	16.2	11	9
10th	8.7	19.3	8	7
11th	10.6	23.6	7	6
12th	12.4	28.6	5	4
13th	14.9	34.8	4	3
14th	19.6	42.3	3	3
15th	21.7	49.7	3	2
16th	26.1	52.8	2	1
1st Rev.	1.9	3.7	55	45
2nd Rev.	1.9	4.3	43	36

The gradeability is based on theoretical values and depends on ground conditions and the coefficient of friction. A minimum speed of 0.6 MPH is in 1st gear(off-road) at 800 rpm.

STERLING CRANE

3. SUPERSTRUCTURE

3.1 SUPERSTRUCTURE FRAME

Connected to carrier by a single-race ball bearing slewing ring with external gearing providing 360° continuous rotation. Central lubrication system for slewing device, boom elevation cylinder and basic bearing.

3.2 CRANE ENGINE

Mercedes Benz 4 cylinder water-cooled diesel engine, model OM 904 LA(EUROMOT 2,EPA), with 177 hp at 2,200 rpm, 486.80 ft-lbs torque at 1,200 - 1,600 rpm. Stepless control of engine rpm by foot pedal.
Fuel tank capacity : 84.53 gal (320 l)

3.3 HYDRAULIC SYSTEM

Three circuit diesel hydraulic system with 1 axial piston variable displacement (hydraulically controlled) double pump with cumulative control for telescoping, derricking and hoisting plus 1 axial piston pump for swing and pilot controls.

3.4 HYDRAULIC CONTROLS

2 joy-stick levers and 4 three-way electrically operated valves for independent simultaneous operation of all crane motions with stepless speed control.

3.5 TELESCOPIC BOOM

Five section box type construction of high tensile, fine grained steel, consisting of 1 base section and 4 telescopic sections. The boom is extended by means of 1 double acting single stage cylinders with integrated holding valves.

All telescope sections can be extended and retracted fully automatic and locked in the selected working position.

All telescope sections are extendable under partial load.

Total retracted length : 42' 5-13/16" (12.95m)
Total extended length : 170' 7-1/4" (52.0m)
Max. sheave height : 180' 5-3/8" (55.0m)
Telescoping speed out : 320 sec.

3.6 BOOM EXTENSION

Swing around lattice type boom extension 31.17'(9.5m) / 53.15'(16.2m), offsets 0° / 20° / 35° with anti-two block system.
24.6'(7.5m) top jib to extended to 79.07'(24.1m).
19.7'(6.0m) intermediate section to extend to 98.75'(30.1m).

3.7 AUXILIARY LIFTING SHEAVE (SINGLE TOP) (OPTIONAL)

Single sheave mounted to main boom head for single line operation (stowable). Equipped with anti-two block system.

3.8 BOOM HOIST

1 double acting hydraulic cylinder with integral holding valve.
Boom elevation : -2° to +82°
Boom elevation speed : 84 sec. normal speed /
42 sec. high speed (only derricking up)

3.9 MAIN WINCH

Axial piston constant displacement motor, grooved hoist drum, integral planetary gear, automatic hydraulically controlled spring-loaded multiple disc brake and integral free wheeling (no sagging of load by hoisting).

Winch drive assembly connected to open hydraulic system. Wire rope with "Superstop" easy reeving system. Lower limit switch and drum turn indicator.

Drum diameter : 20.67" (525mm)
Rope diameter : 0.83" (21mm)
Rope length : 820' (250m)
Max. line pull 1st layer : 21,356 lbs. (95 kN)
Max. line speed 4th layer : 426.5 ft/min (130m/min)

3.10 AUXILIARY WINCH (OPTIONAL)

Axial piston constant displacement motor, grooved hoist drum, integral planetary gear, automatic hydraulically controlled spring-loaded multiple disc brake and integral free wheeling (no sagging of load by hoisting). Winch drive assembly connected to open hydraulic system. Wire rope with "Superstop" easy reeving system. Lower limit switch and drum turn indicator.

Drum diameter : 20.67" (525mm)
Rope diameter : 0.83" (21mm)
Rope length : 820' (250m)
Max. line pull 3rd layer : 21,356 lbs. (95 kN)
Max. line speed 4th layer : 426.5 ft/min (130m/min)

3.11 SLEWING GEAR

Constant displacement motor with three stage planetary gear, a foot actuated or automatic service brake and a parking brake. Open hydraulic circuit with free slewing function. Slewing speed infinitely variable: 0 - 1.7 rpm

3.12 COUNTERWEIGHT

Total 77,160 lbs, divisible, assembled and disassembled by hydraulic cylinders controlled from crane cab.
Tail swing : 13' 5-7/16" (4.10m)

3.13 SUPERSTRUCTURE CAB

Spacious comfortable panoramic cab with sliding door, extra-large tinted glass windows, electrical fold-out front window with windshield washer and wiper, fixed cab roof window with armoured glass and washer/wiper, sun visor, cab light, tiltable cockpit with adjustable hydraulically cushioned seat with headrest, signal horn, radio with CD player, and connection for wireless (12 volt). Engine dependent hot-water heater and engine independent hot water heater with engine pre-heat. Complete controls and instrumentation plus LCD graphic display for crane operation. Outrigger controls from superstructure cab and supported forces display.(OPTIONAL)
Air conditioner.(OPTIONAL)

3.14 ELECTRICAL SYSTEM

24 volt system with 30 A 3-phase alternator, two 12 V (110 Ah) batteries, 1 rotating beacon on left-hand side of main winch, 2 working lights on cab front flap, 1 working light on boom base section and 2 side lights on boom head.

3.15 SAFETY DEVICES

Electronic load moment device (ASLI) with interpolation and automatic overload shut-off, hoist limit switch with shut-off, overload warning and load moment gauge. Anemometer. Digital display of boom angle, boom length, sheave height, working radius, hook load and further information. Working area limitation for lifting height, load radius, boom angle and swing range. Safety valves against pipe and hose rupture, holding valves on hydraulic cylinders.

3.16 SUPERSTRUCTURE OPTIONAL EQUIPMENT

1. Air conditioning
2. 11 ton headache ball
3. 27.5 ton, 1 sheave single hook block
4. 69.4 ton, 3 sheave ram's horn hook block
5. 88.0 ton, 5 sheave ram's horn hook block
6. 138.0 ton, 7 sheave ram's horn hook block
7. Auxiliary winch
8. Auxiliary lifting sheave
9. 24.6' top jib for boom extension
10. 19.7' intermediate section for boom extension
11. 11.48' Heavy-lift jib
12. Spark arrester
13. Aircraft warning lamp
14. Drive/steer and outrigger control from crane cab
15. Outrigger load monitors with display in superstructure cab and outrigger control panels.
16. Additional hydraulic oil cooler
17. Working area limitation(Slew limit)
18. Free slewing and free boom elevation circuits for boom dolly.
19. 360° positive swing lock (NYC requirement).

STERLING CRANE

DIMENSIONS

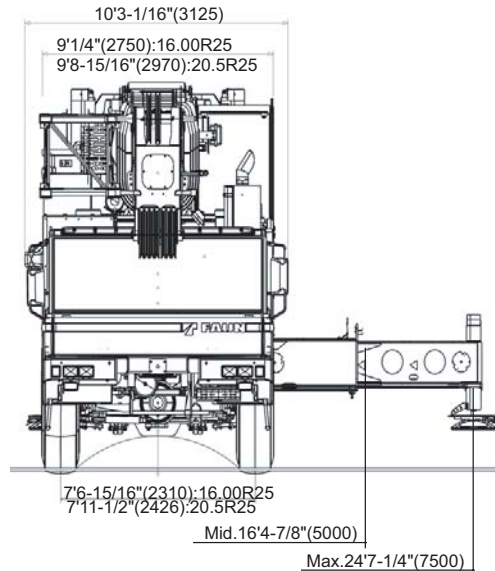
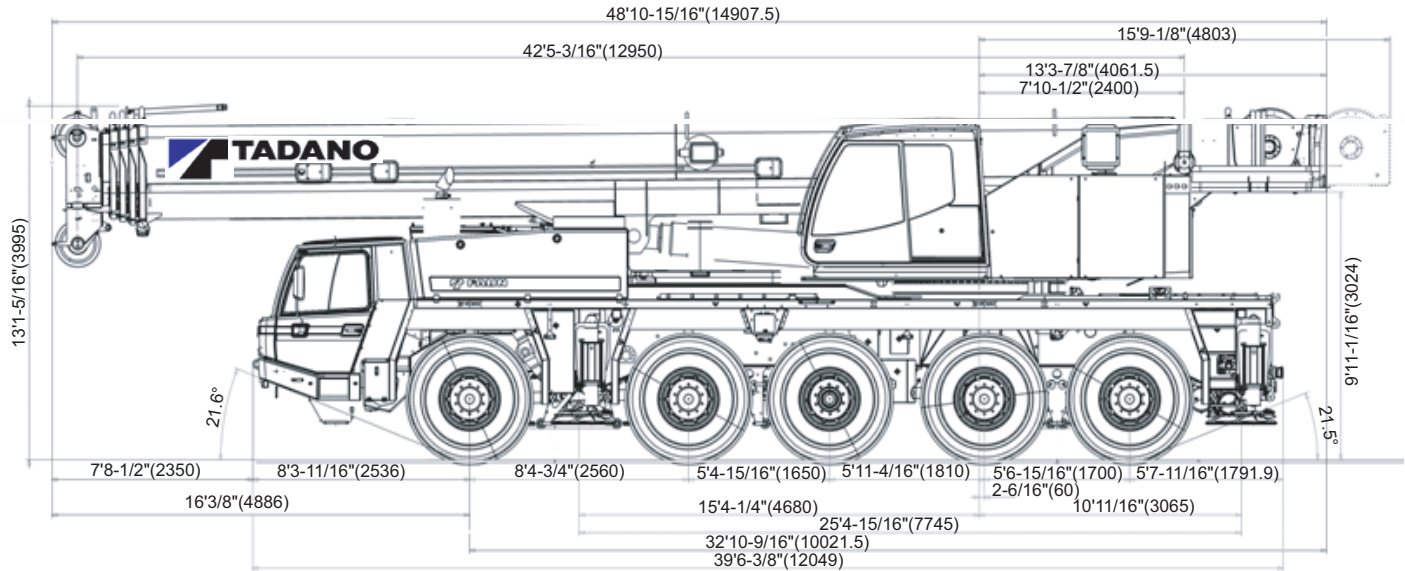

TURNING RADIUS

Steering	Front wheel (10x4)	All wheel (10x8)
Carrier inside	19' 8-1/4" (6.0m)	16' 4-7/8" (5.0m)
Over carrier	38' 3-5/8" (11.675m)	34' 1-7/16" (10.4m)
Over boom	41' 4-1/16" (12.6m)	37' 8-3/4" (11.5m)
Over boom extension	43' 7-5/8" (13.3m)	39' 7-3/8" (12.075m)

Specifications are subject to change without notice.

STERLING CRANE

ATF110G-5 Axle weight distribution chart

1) Normal traveling condition

	GVW	Axle 1	Axle 2	Axle 3	Axle 4	Axle 5
Base machine with 16.00R25 tires, no counterweight, no fuel, no driver	104,471	22,213	22,978	22,050	18,713	18,517
Add:						
1. 11.0 ton hook ball (in carrier storage)	441	73	73	0	148	148
2. 27.5 ton hook block in front	662	592	592	0	-261	-261
3. 69.4 ton hook block in front	1,323	1,195	1,195	0	-534	-534
4. 88.0 ton hook block in front	1,764	1,618	1,618	0	-736	-736
5. Boom extension (31.2ft/53.1ft) stored on main boom	3,669	2,277	2,277	0	-443	-443
6. Auxiliary winch with cable	3,109	-949	-949	0	2,503	2,503
7. Auxiliary boom point sheave (single top)	181	185	185	0	-95	-95
8. Drive 10x8	298	147	147	0	2	2
9. Drive/steer and outrigger control from crane cab	93	37	37	0	10	10
10. Air conditioning in carrier cab	108	77	77	0	-23	-23
11. Air conditioning in crane cab	106	-12	-12	0	65	65
12. Tool box at rear	154	-39	-39	0	116	116
13. Additional Hydraulic oil cooler	88	-7	-7	0	51	51
14. 20.5R25 tires in lieu of 16:00R25	1,036	207	207	207	207	207
15. Air & electrical circuits to rear for boom dolly	24	-4	-4	0	16	16
16. Free swing & boom hoist circuit for boom dolly	62	4	4	0	27	27

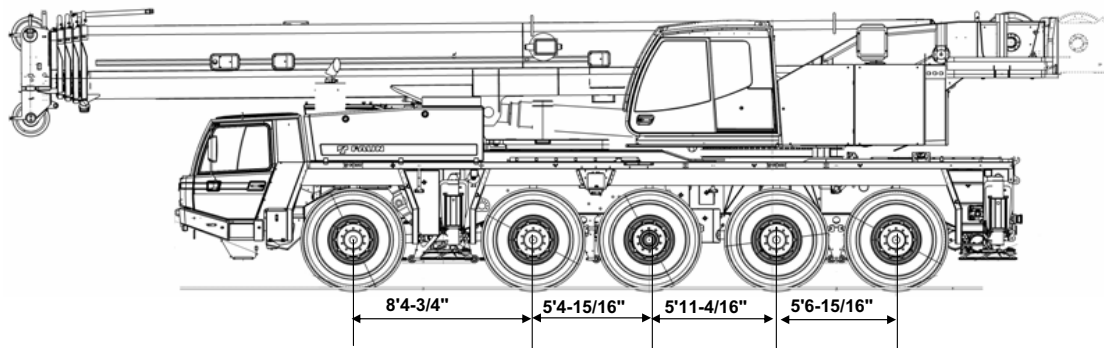

2) Traveling with boom dolly

	GVW	Axle 1	Axle 2	Axle 3	Axle 4	Axle 5	Boom Dolly
Base machine with 16.00R25 tires, no counterweight, no fuel, no driver	104,471	16,118	16,916	17,237	16,314	16,118	21,768
Add:							
1. 11.0 ton hook ball (in carrier storage)	441	73	73	0	148	148	0
2. 27.5 ton hook block at boom head	662	0	0	0	0	0	662
3. 69.4 ton hook block at boom head	1,323	0	0	0	0	0	1,323
4. 88.0 ton hook block at boom head	1,764	0	0	0	0	0	1,764
5. Boom extension (31.2ft/53.1ft) stored on main boom	3,669	-1,680	-1,680	0	3,514	3,514	0
6. Auxiliary winch with cable	3,109	1,455	1,455	0	100	100	0
7. Auxiliary boom point sheave (single top)	181	0	0	0	0	0	181
8. Drive 10x8	298	147	147	0	2	2	0
9. Drive/steer and outrigger control from crane cab	93	-37	-37	0	83	83	0
10. Air conditioning in carrier cab	108	77	77	0	-23	-23	0
11. Air conditioning in crane cab	106	29	29	0	24	24	0
12. Tool box at rear	154	-39	-39	0	116	116	0
13. Additional Hydraulic oil cooler	88	22	22	0	23	23	0
14. 20.5R25 tires in lieu of 16:00R25	1,036	207	207	207	207	207	0
15. Dolly brackets at boom	141	0	0	0	0	0	141
16. Towing attachment(190 kN)	198	0	0	0	99	99	0
17. Air & electrical circuits to rear for boom dolly	24	-3	-3	0	15	15	0
18. Free swing & boom hoist circuit for boom dolly	62	7	7	0	24	24	0
19. 2 Axle Dolly	6,000	0	0	0	0	0	6,000
20. 3 Axle Dolly	9,000	0	0	0	0	0	9,000

