

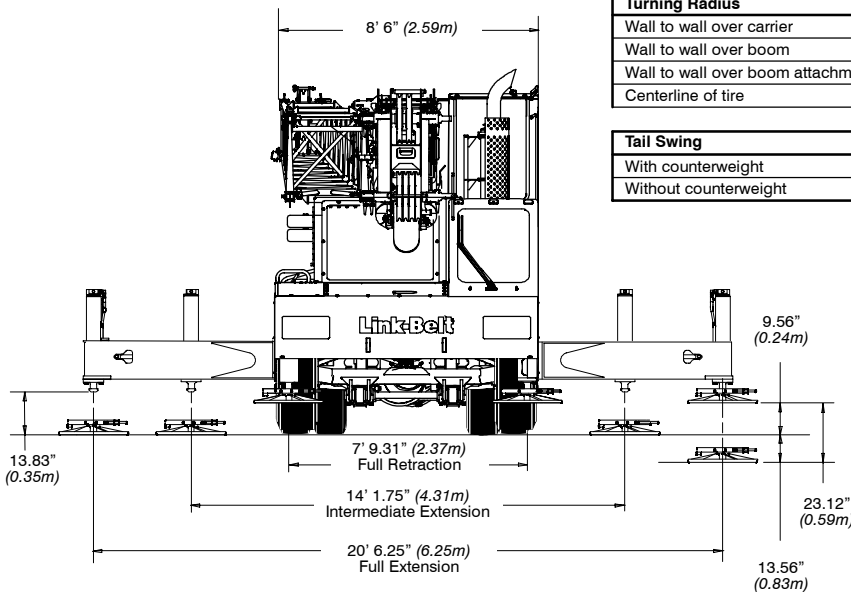

LIFTING CHARTS - Hydraulic Truck Cranes

LINK-BELT MODEL HTC-8660 II - 60 TON CAPACITY

General Dimensions

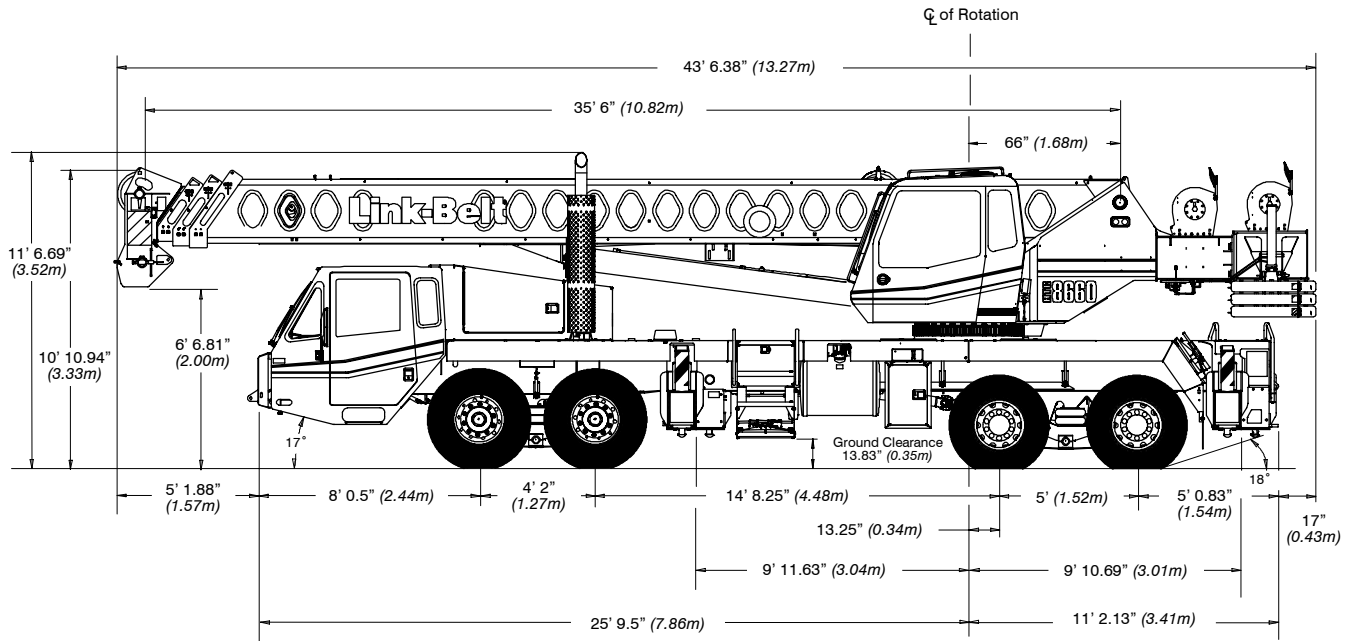

Turning Radius	English	Metric
Wall to wall over carrier	44' 1"	13.4m
Wall to wall over boom	45' 6"	13.9m
Wall to wall over boom attachment	46' 11"	14.3m
Centerline of tire	38' 7"	11.8m

Tail Swing	English	Metric
With counterweight	12' 8.5"	3.9m
Without counterweight	12' 5.25"	3.8m