

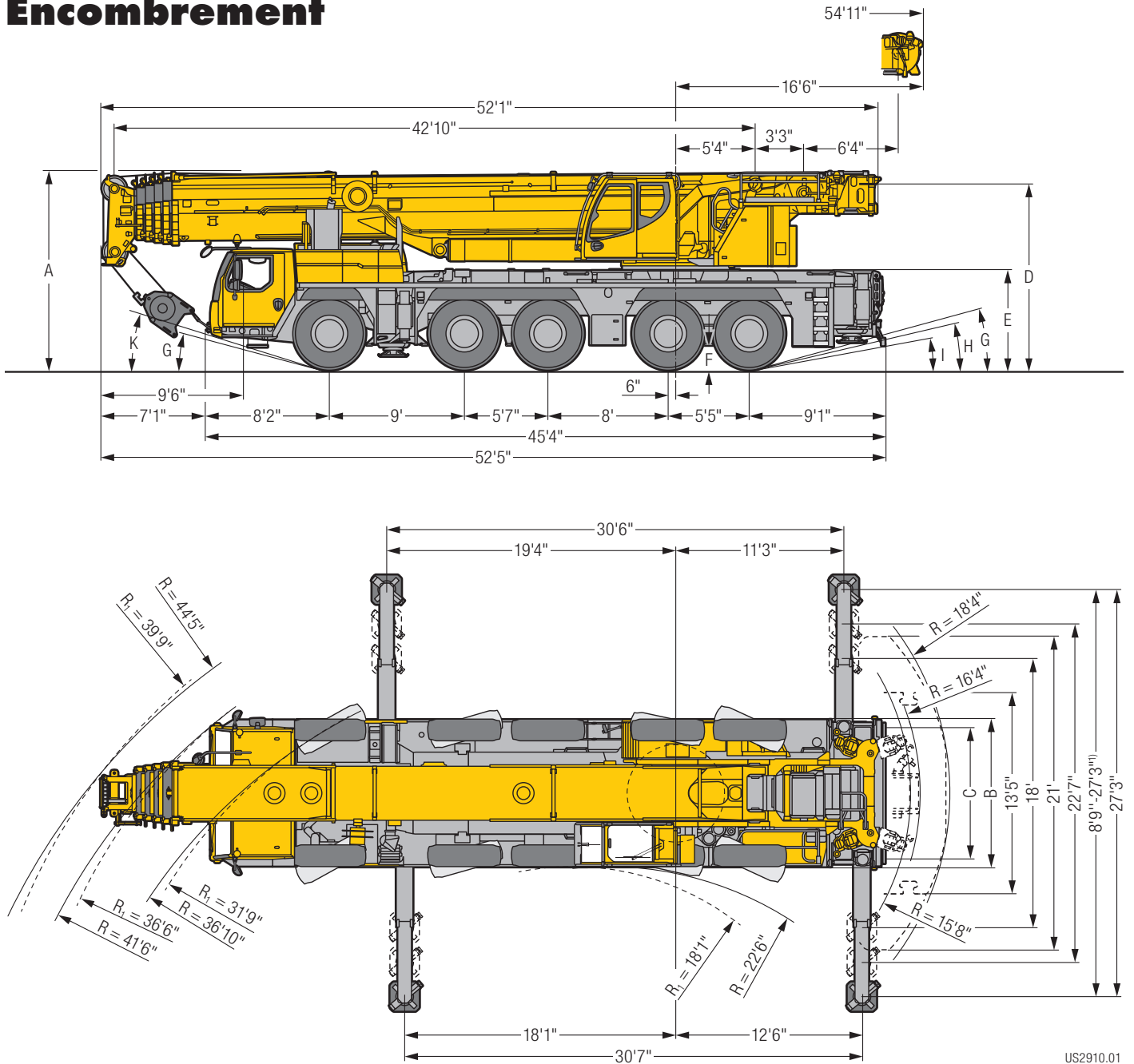

LIFTING CHARTS - All Terrain Cranes

LIEBHERR MODEL LTM 1250-5.1 - 300 TON CAPACITY

Dimensions Encombrement



US2910.01

R₁ = All-wheel steering · Direction toutes roues

¹⁾ only with VarioBase® · seulement avec VarioBase®

Dimensions/Encombrement

	A	A	B	C	D	E	F	G	H	I	K
		5"*									
445/95 R 25 (16.00 R 25)	13'1"	12'9"	9'10"	8'4"	12'4"	6'7"	1'5"	14°	13°	10°	17°
525/80 R 25 (20.5 R 25)	13'1"	12'9"	10'2"	8'5"	12'4"	6'7"	1'5"	14°	13°	10°	17°

* lowered · abaissé

STERLING CRANE

Counterweight Contrepoids

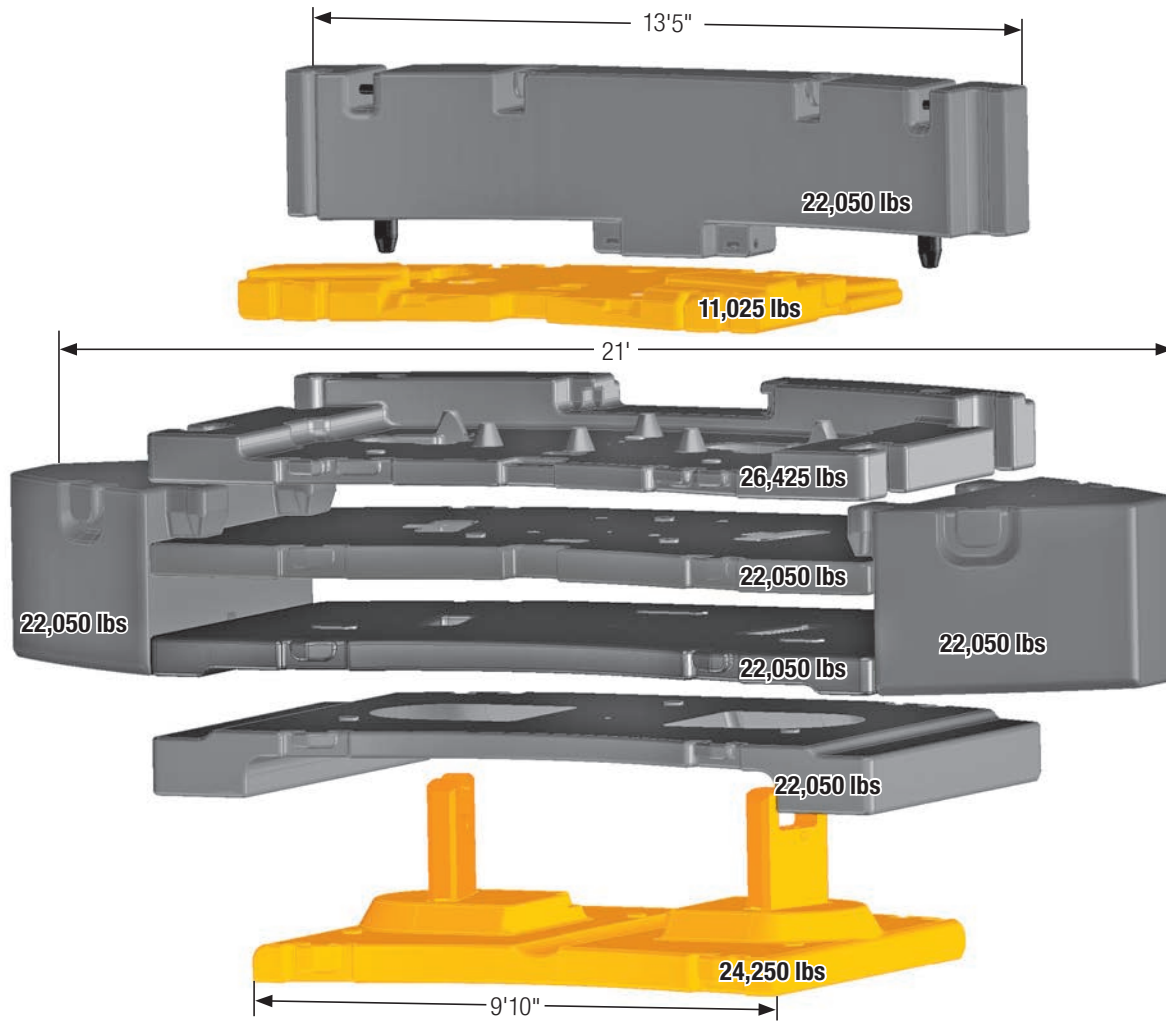
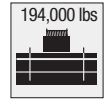

Technically transportable · Transport techniquement simplifié

Axle/Essieu

Axle Essieu	1	2	3	4	5	Total weight lbs Poids total lbs
lbs	26,400	26,400	26,400	26,400	26,400	132,000 ¹⁾

¹⁾ with sheave set · avec jeu de poulies

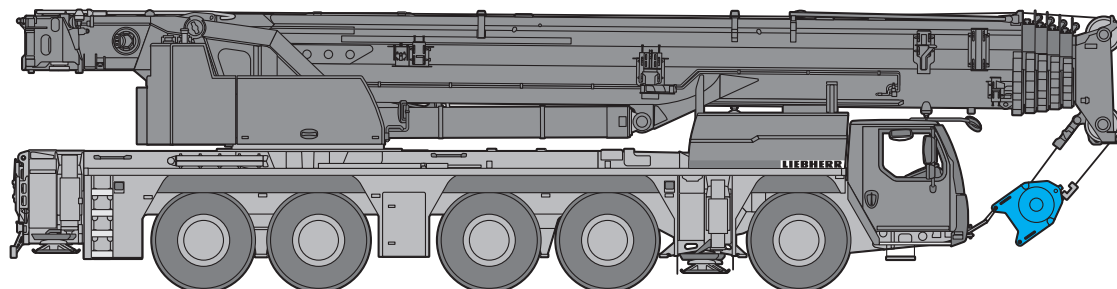

S2967