



TRANSPORTATION SPECS - Crawler Cranes

DEMAG MODEL CC2400-1 - 440 TON CAPACITY

<u>COMPONENT WEIGHTS</u>	<u>LBS.</u>	<u>KGS.</u>	<u>MAIN BOOM 78.7' – 275'6" (24m – 84m)</u>		
Complete Crane C/W 84m Boom, 30m Mast, Full Counterweight and 2 x 160T Blocks	708,108	321,196	<u>Tubular 9'9"W x 8'2"H</u>	<u>LBS</u>	<u>KGS</u>
Superstructure c/w Mast & Winches (43'4" x 10' x 6'5")	99,648	45 200	Boom Butt 10.9m (35'6" x 9'9" x 9'8")	24,250	11 000
Carbody c/w Outriggers (22'4" x 10' x 3'8")	42,108	19 100	Boom 6m (21'8" x 9'9" x 8'2") 2 pc.	6,393	2 900
Tracks – 440-4-2709 (33'8" x 4'4" x 5') ea.	51,588	23 400	Boom 12m (41'4" x 9'9" x 8'2") 5 pc. ea.	12,346	5 600
Tracks – 440-4-2710 (33'8" x 5' x 5') ea.	53,792	24 400	Boom Reducer (40' x 9'9" x 8'2")	13,007	5 900
			Boom Tip (11'2" x 8'4" x 11'3")	9,700	4 400
<u>Counterweights:</u>			<u>Superlift Mast 98' or (30m)</u>		
160t of Main Counterweights			<u>Tubular 7'6" W x 6'H</u>		
Base Plate (22' x 7'9" x 2')	44,092	20 000	Mast Butt 6m (20'3" x 8' x 6')	14,991	6 800
14 – 10t Cwts. (7'9" x 6' x 1'8") ea.	<u>22,046</u>	<u>10 000</u>	Mast 12m (40' x 7'5" x 6'5)	8,598	3 900
	352,736	160 000	Mast Tip 12m (40'8" x 8'7" x 9'3")	18,739	8 500
41.6t of Carbody Counterweights					
2 – 10.6t Cwts. (7'3" x 8'10" x 2'8") ea.	23,369	10 600			
2 – 10t Cwts. (7'9" x 6' x 1'6") ea.	<u>22,046</u>	<u>10 000</u>			
	<u>90,830</u>	<u>41 200</u>			
	443,566	201 200			
<u>Additional Components</u>			<u>Luffing Jib 78.7' – 275.6' (24m – 84m)</u>		
2 x 160t Block (8'3" x 2'7" x 4'8")	15,212	6 900	<u>Tubular 8'6" W x 6'6" H</u>		
100 Ton Block (5'9" x 2'4" x 3'6")	8,267	3 750	Luffing Masts (55'2" x 8'7" x 6'3")	11,905	5 400
50 Ton Block (6'2" x 2'6" x 1'6")	6,393	2 900	Luff Butt 5.5m (17'1" x 8'4" x 9'4")	4,630	2 100
Container of Accessories (19'9" x 8' x 8'7")	13,228	6 000	Insert 6m 2 pc.	3,858	1 750
Two (2) Outriggers (11' x 4' x 3'6")	4,409	2 000	Insert 12m 5 pc. ea.	7,275	3 300
Tray (24' x 7'7" x 3'3")	9,920	4 500	Tip Section 8m (26'3" x 8'7" x 10'1")	9,590	4,350
Runner (8' x 5'7" x 6'3")	1,829	830			
H1 Winch	12,544	5,690	<u>Fixed Jib 39' – 118' (12m – 36m)</u>		
H2 Winch	8,818	4,000	<u>(Only Available on 440-4-2709)</u>		
			<u>Tubular 6'5" W x 5'H</u>		
			Fixed 12m c/w Strut (41'8" x 7' x 12'6")	9,260	4 200
			Insert 12m (40' x 6'5" x 4'8")	2,645	1 200
			Fixed Tip 12m (21'2" x 6'5" x 4'8")	2,645	1 200

STERLING CRANE

SPECIFICATIONS

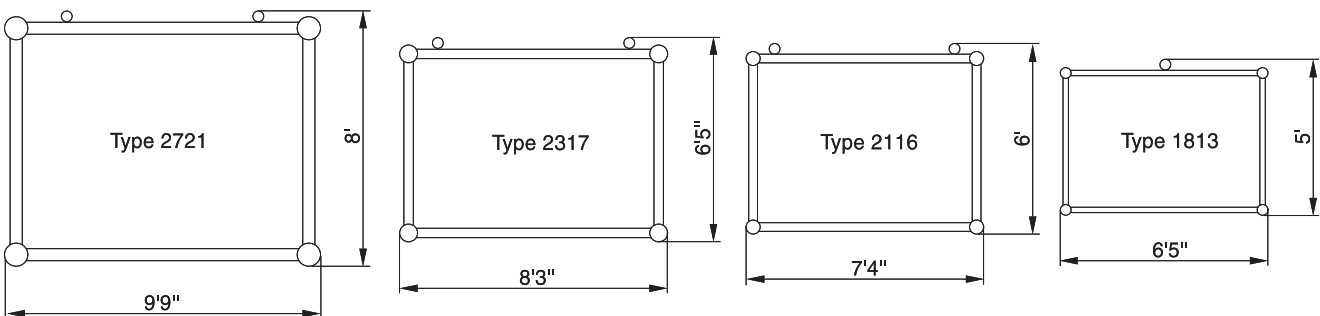
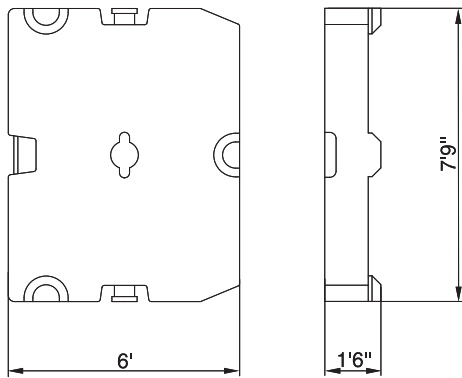
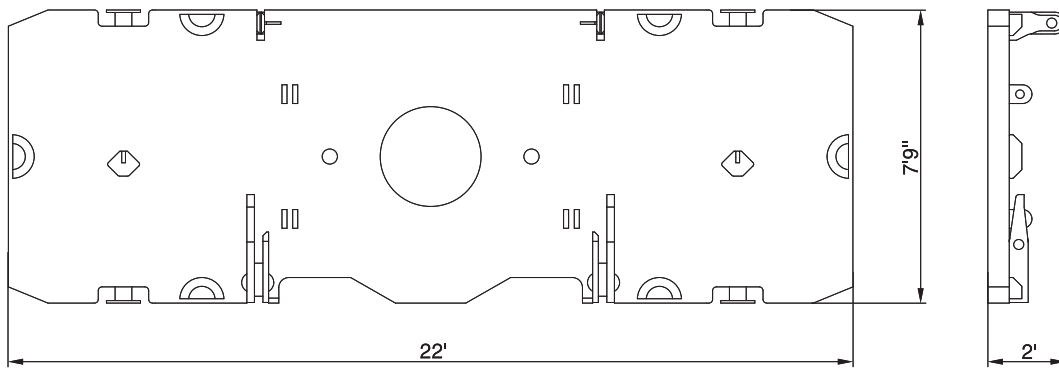
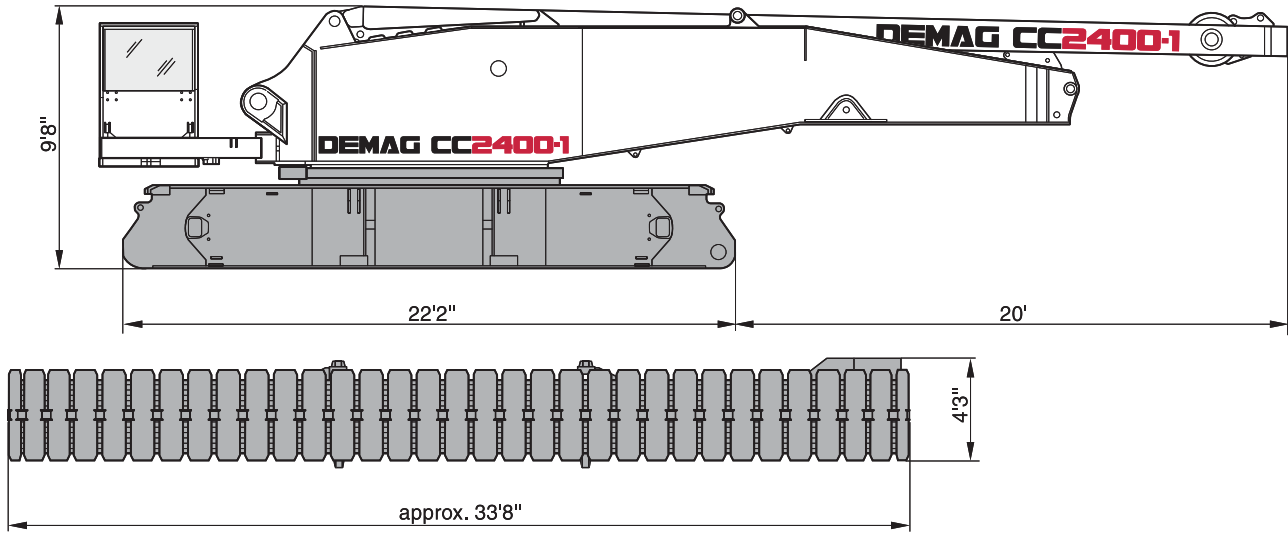



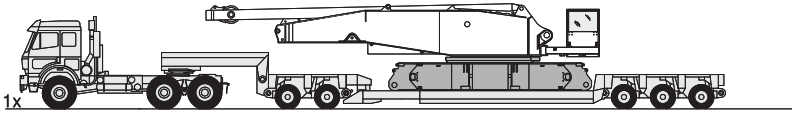

STERLING CRANE

TRANSPORT EXAMPLE FOR CC 2400-1

Load approx. 131,400 lb



-  Counterweight 353,000 lb
-  Basic crane
-  Boom combination SWSL 236.2 + 275.6 ft
-  Container with tools, rigging gear, etc.
-  Boom combination LF 118.1 ft

Load approx. 53,800 lb

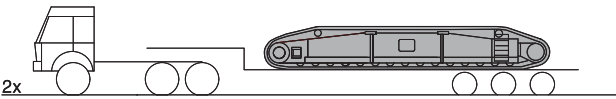

Load max. 52,910 lb

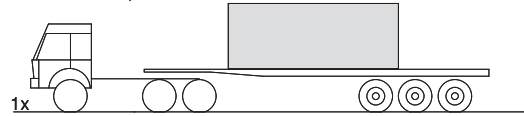

Load 53,800 lb

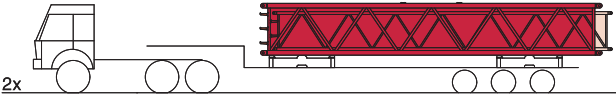

Load 10,580 lb

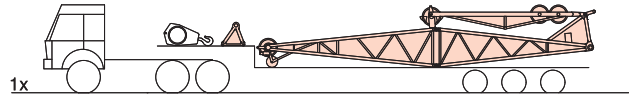

Load 62,170 lb

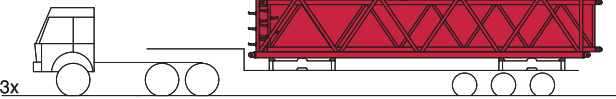

Load 12,570 lb

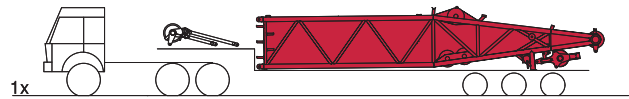

Load 55,560 lb

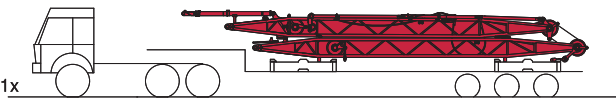

Load 57,320 lb

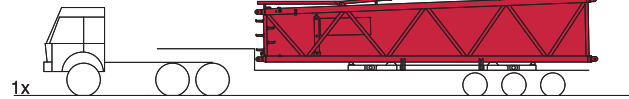

Load 18,740 lb



Load 36,820 lb

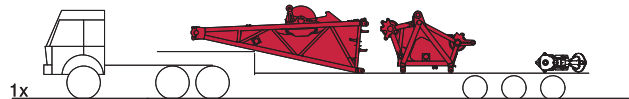

Load 27,560 lb

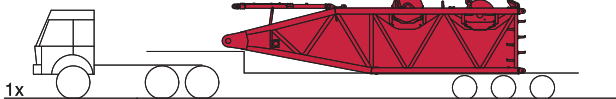

Load 58,200 lb



Load 49,160 lb

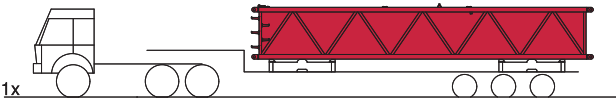

Load 13,890 lb

